



A Review on Optimal Siting and Sizing of D-STATCOM

Kkx-k"us Ukkvffa o-voff⁵0H2Hl n` wuk"sw⁵⁰ [ID 0V2] 2V uy"so⁵0HnkW` Oksv` Ql s"o⁶ [ID 0] Zkx s Zkw sx` 7⁰⁸ [ID 0] U2M" u⁹ [ID 0] 0H2H2V wyffono⁹0P2ZZT kn` q` :0H2] 2S kKkx: 0P-Kkns Ok-ffsw Yy-wk" [ID 0]

- ⁵Lvom⁵ snkvLx qsx oo" sx q Koz k" w ox" 0Hr w kn` I ovy] x sR⁵A-s"ff0d k"skIU sqo"sk
- ⁶Lvom⁵ snkvkx n Lvom⁵ yx sm- Koz k" w ox" 0[k"kl k Z"l o] x sR⁵A-s"ff0d qy IU sqo"sk
- ⁷Z"o RoffSk y" k"y" ffypYovkl s s"ffkx n B" owsqox no ypLvom⁵ snkvL` sz w ox" 0Ool os] x sR⁵A-s"ffyp[onn xyw qff[skx tsx 7445740J r sk
- ⁸I syw onsnkvLx qsx oo" sx q Koz k" w ox" 0] x sR⁵A-s"ffypRy" sx 0W2I 2 259590Ry" sx IU sqo"sk
- ⁹[ovonyw w` x snk" syx Znsox no Koz k" w ox" 0] x sR⁵A-s"ffypRy" sx IU sqo"sk
- ¹Lvom⁵ snkvLx qsx oo" sx q Koz k" w ox" 0Rkxy] x sR⁵A-s"ffypZnsox no) [onn a ` nsvIU sqo"sk
- ¹Lvom⁵ snkvLx qsx oo" sx q Koz k" w ox" 0I kffo"y] x sR⁵A-s"ff0Rkxy IU sqo"sk
- ¹Lvom⁵ snkvLx qsx oo" sx q Koz k" w ox" 0] x sR⁵A-s" k-Y sk` 0B nxy o-sk

HI Z[J [A o nyx" sx` y` - nowkx n py" ovom⁵ snkv ox o" qff l ff sn` -" so- kx n nyw o"- sm` -o- r kR⁵A"- o-on "r o ovom⁵ s s"ff nyx- w z" syx` y k r sqr voR²A I onk` -o wy"- nywzyxox"- ypnwyo"- snkx n sn` -" skv- ff"- ow- k" o wkno ypzyKA" ovom⁵ yx sm- noR⁵A- s- "r os" no- sq- 2B knns" syx 0wyno" x ovom⁵ snkvzyKA" ns"- sl` " syx xo" KA" u-, KU- k" o- l tomon" y wkty" ns"- l kx no- 2 J yx- o' ` ox" vff" ynkff"- zyKA" -ff" ow s- vknox KA" r zyKA" ' ` k s"ff z" yl vow- -" n k- o- l no- sR⁵A ox o" qff wy- o- 0R⁵A" kqo noR⁵A" syx- 0 zyy" zyKA" pkn"y" , WM0 R⁵A" kqo s- "kl s s"ff kx n "ovkl s s"ff s- o- "y wox" syx on t' -" k pK²A[y py" o- "kw" r o- o ns"- l kx no- 0 Ks"- sl` " syx Lx qsx oo"- r kR⁵A s" yn` non" r o` -o yp] -" yw WyKA" KoR⁵A- , J WK- s x y" no" y "on` no zyKA" wy- o- y k- swz" yR⁵A zyKA" ' ` k s"ff2 Hw yx q- " J WK- 0 Ks"- sl` " syx Z" k sm] ywz ox- k" y" , KIZ[H[J VT- z" yR⁵A wy- " z" yws- s x q s x w s s w s f f x q zyKA" ' ` k s"ff s- o- l onk` -o s" qox o" k- o- w s s w k v r k" w y x s m 0 K k" o vo- zyKA" 0 r k- -wkw- s f f 0 r sqr " oq` k" y" ff nkz kl s s"ff kx n ny- " o on s R⁵A Yo- ok" n r o- s- " onox" ffok"- r kR⁵A py n i- on yx wo" r ny nyw y qso- " o' ` s" on py" snox" s f f s x q" r o wy- " - s" kl vo ynk" syx kx n " k" s x q yp KIZ[H[J VT noR⁵A l k- on yx nsR⁵A qox" R⁵A K² O y K A R⁵A 0" y nk" o 0y x v f y x o k" r y" r k- -y p k" " o R⁵A K² n k z k o" yx " r s- k- z om" yp- " n f f 2 s- z k o" ns- m- o- " r o v k" o- " n f f yx k z z" yz" sk" o s- " kvk" syx kx n " k" s x q yp KIZ[H[J VT " onn x s' ` o- py" l k k x n o n kx n ` x l k k x n o n " knk s v n s"- sl` " syx xo" KA" u-,] I YKU- 2 o z k o" r k- k v y z" y R⁵A on k nywz" or ox- s R⁵A s" o" k" o -" n f f yx " r o ynk" syx yp KIZ[H[J VT s x YKU- py" zyKA" wy- " on` m s yx kx n zyKA" ' ` k s"ff ox r kx n o w ox" 2 J ywz k" k" s R⁵A k x k f f- o- yp R⁵A s y' - " onn x s' ` o- py" noR⁵A yz w ox" yp KIZ[H[J VT V l ton s R⁵A p x m s yx- kx n nyx- " k s x" - B T o" s' - kx n Kow o" s' - k" o z" o- ox" on 2

Roff KA" n- A K s"- sl` " syx Z" k sm] ywz ox- k" y" 0V z" sw s f f x" syx 0W y KA" ' ` k s"ff 0 KIZ[H[J VT J yx" yv- " k" o qso- 0 KIZ[H[J VT - s f f x q 0 p x m s yx- kx n -" m" o 0Y o R⁵A K A

1. INTRODUCTION

I y" r nyw o"- sm kx n sn` -" skv nowkx n py" ovom⁵ s s"ff qyl k f f s- - r y y" s x q ` z qoyw o" snk w f 2 Lvom⁵ snkv ox o" qff s x- "kl s s"ff s- k- y n k" on KA" r" o oR⁵A l q" y KA" q ns o" ox no l o" KA ox Wyn` m s yx ox n kx n " r o s x m i o k- s x q f f r sqr nowkx n p" y w " r o nyx- w o- " nyw k s x 2 s- s- o R⁵A ox" s x sn` -" skv ox R⁵A y w ox"- kx n " o- snox" skv nyx- w z" syx z k o x- 2 Z o R⁵A k v s" o" k" " o- -" n k- e 5 19 g z" o- ox" on " r k" k- w y x q k- " r o" o s- s x m i o k- o s x nowkx n py" ovom⁵ snkv ox o" qff kx n nyx" sx` y` -" s R⁵A py" on xyw s m l` y f f k x n f f 0" r ox 0 s x n` -" so- kx n nyw o"- sm nyx- w o- " KA" v n ny o" no ` " s s"ff nyw z k x so- "y yz o" k" o" k" " r os" zoku o ns ox n f f l y` x n k" so- 2 o- o nowkx n- r k R⁵A o l h y- on " r o zyKA" -ff" ow "y -oR⁵A o z" yl vow- 2 Zywo yp" r o " o k" on x o" KA" u- z" yl vow- s x m" no A o l h y- s R⁵A zyKA" wy- o- kx n R⁵A k q o n" yz- s x x o" KA" u l` -o- e: g 2

Bk 645: 0 W k u k- r) R r k" y n e; g " o z y" " on " r k" " r o z" yl vow- k" o k- y n k" on KA" kns R⁵A y k n- " r k" nyw s k" o" r o z" o- ox" nk f f zyKA" -ff" ow- 2 K s"- sl` " syx s x- o- r k R⁵A r sqr

" o- s- l k x n o" y s w z on k x n o" k" s y 0 k x n w y" o s x n` m s R⁵A y k n- k" o y ox k n n o n yx " r o s x o- " o v k" s R⁵A y" r o q" y KA" q z y z" v k" syx nowkx n 2 o " o- v k x" o on i- k" o R⁵A k q o n" y z- s x l` -o- yp yx o z r k- o kx n " r o o l z r k- o ` x l k k x n o n w y k n- 2 H v y 0 " r o s x" yn` m s yx yp KN- s x " y n k f f- KU- nk` -o " o R⁵A k v- yp zyKA" y KA s x s x o- B" r s- s- x r o k v r f f py" " r o -ff" ow e= g 2 H" r y" - s x e @ KA" o " r k" " y n k f f- zyKA" ovom⁵ yx sm- noR⁵A- k" o wy- " o v o R⁵A py" zyKA" ' ` k s"ff s w z" y R⁵A w ox" l onk` -o yp " r os" p k"- l y z o" k" s x q" s w o kx n ny- " o on s R⁵A o- nyw z k" on "y " r o " kns" syx kv ovom⁵ yw on n k x snkv noR⁵A- " r k" k" o -y KA s x yz o" k" syx kx n o l h o x- s R⁵A

P r k- l o o x - r y KA " r k" zyKA" ovom⁵ yx sm- l k- on nyx" yw o"- s x K Z q` k" k x" oo- " ns ox" ox o" qff k" no- s" on voR⁵A

Received : Qx` k"ff6806465
 Revised : Qff5; 06465
 Accepted : Konow l o" 6406465

yp' kvs'ffpy' -l -nsl o- e54g2J WK- KAsnr zo'py'w "ok'on p'xmsyx vsuo MHJ [Z noRso- k'o "ovoRA" yz'syx "y "o-yRA "ynkff- z"yl vow yp sx "o" z'syx- sx KZ2Hv'ry' qr MoTh vo Hv'o'xk'sxq J "ox" ["kx-ws-syx Zff'ow ,MHJ [Z- kxn J WK- k'o yp -kwo "onxywyqf0 ryKARo0 "r off zo'py'w ns o'ox" p'xmsyx-2MHJ [Z noRso- k'o -on sx "kx-ws-syx -ff'ow0J W- k'o -on sx KU- e55g2 J WK- k'o xy'wkwff kzzvson KAox zyKA' ' kvs'ff0-ff'ow -"kl ss'ff kxn "ovskl ff s- "r o nowkxn sx zyKA' -ff'ow-2a r ox z "yz o'ff swz vow ox" on0 KIZ[H[J VT nix z "y" omi "r o -ff'ow kqkxs- 1 kix non kxn `xl kix non RA'kqo noRA'syx-) m "ox" r k'wysm- e55g2P kv-y z "y" omi kqkxs- RA'kqo smio-0 -kq-0 -KAw- kxn yKA zyKA' pkn'y"2 e58g -"k on "r k" KIZ[H[J VT s- -on "y "o-yRAzyKA' ' kvs'ff s- o- vsuoAzp0RA'kqo z "y vo) RA'kqo -"kl ss'ff2P kx ox o'qff -y' "no y" ffkAoo v s- nyxx omion "y s' nix o'lim kxqo l y" r knisRA kxn "oknisRA m "ox" KAr "r o xo"KA' u2

Bk kxy"r o" noRAyzw ox" k" ry" -sx e59g o'lim kxon "r k" "r o noRA z "yRAo- RA'kqo -" zzy" kxn ns' m' k' o -" z v -zyKA' kwyxq- "r o zrk-o- kxn kv-y ws'sqk'o- zyKA' "oRA- kv- nk' -on l ff W_ Z2KIZ[H[J VT sx- "kvw" syx sx KU- nix swz "yRA" r o o nsox nif yp W_ -ff'ow- e5: g2

Vz sw' w sx- "kvw" syx kxn "k" sxq yp KIZ[H[J VT noRA- s- l k-on yx s' - onxywsm swzy" kxn no -" kxn k' n "ovskl ss'ff kxn kRAkkl ss'ff py' -o e5; g2 OyKARo0 s' s- yl -o"RA "r k" wy- "oRAKAn KA' u- KA' o qok'on "yKA' n- yz" sw' w z k'now ox" kxn -sfxq yp MHJ [Z KoRA- sx "kx-ws-syx xo"KA' u-0l " poKAx "r o yz" sw' w kwynk" syx yp J WK- sx] I YKZ2

J k'op v- " nff yp "o-ok" n on z' l vnk" syx- -ryKA "r k" yx ff "KAx" fl RA, 69- Wz o- r kRA- y jk' l oox z' l w- r on p' yw 6456 1645@yx ns "o" x" k- z omi- yp" r o z "yl vow -" xno" "oRAKA s- xono- s" k on py' p "r o" -" nff yx yz" sw' w kwynk" syx yp KIZ[H[J VT noRA- l k-on yx "r o kRAkkl vo "onm xs' -o 0 yl tonisRA p' xmsyx-0 nyx- "kx" -0 wo" s- kxn nowo" s- 2

s- zko" r sqr sqr - yx -oRAkv "o-ok" n on KA' u- yx yz" sw kvkwynk" syx yp KIZ[H[J VT noRA- s- l kix non kxn `xl kix non KZ2 o nym w ox" s- y" qkx sfon "r -A Zom'syx 6 s- sx "yn' m'syx "y nywzyxox"- kxn -o- yp KIZ[H[J VT 2 YoRAKA yp yz" sw kv -s" sxq kxn "k" sxq "onm xs' -o- yp KIZ[H[J VT z "o-ox" on sx Zom'syx 72 Zom'syx 8 s- ns-m- syx yx KIZ[H[J VT nyx "yv- "k" oqso-2 Zom'syx 9 s- "onywwox nk" syx- py' p "o" -" nso-0 KAso -om'syx : nyx n' no- "r o" oRAKAn KA' u2

2. INTRODUCTION TO COMPONENTS AND USES OF D-STATCOM

s- om'syx no-nsl o- "r o nywzyxox"- yp KIZ[H[J VT kxn s- swz vow ox" k" syx "y ws'sqk'o zyKA' ' kvs'ffz "yl vow -2

625 KIZ[H[J VT -" m' " o kxn p' xmsyx-

o KIZ[H[J VT s- k -r' x" nyxx omion0 RA'kqo -y' "no nyxRA" o' ,_ZJ - "r k" KAox sx- "kwon k" WJ J qox o' k' o- y" kl -y' l - knisRA kxn "oknisRA m "ox" -2 P' s- k zyKA' ovom' yx smnoRA "r k" r k- "r o nkz kns" ff" y nyxRA" KJ RA'kqo "y HJ RA'kqo, sxRA" o-2 o nywzyxox"- yp "r o noRA- s- n' noAk nmox o' qff -y' kqo l k o' ff y" k ffkAoo v "szw v o" kxn ny' z vxq "kx- py" wo" py' wk' nix sxq "r o

sxRA" o' y' "z" RA'kqo KAr "r o l - RA'kqo2 o _ZJ s- no-sxq on -sxq INI [kxn T VZML[py' -KAsnr sxq z' "zy-o-B kxn s' yz o' k' o- yx "r o z "sxnsz wo- yp W6 T e5=g2

o "yzwyqso- yp KIZ[H[J VT sx n' no-A "r "oolzrk-o "r "oolKAo, 7W8 a - kxn "r "oolzrk-o py' "IKAo , 7W8 a - `xl kix non ns- "s" syx xo"KA' u- e5@2P nix kv-y KA' u k- k -ffxnr "yxy' - RA'kqo sxz " k" ns o' ox" RA' o- kxn zrk-o kxqo2

Mq "o 5k kxn l sw' -"k" o- k -sxqo vx o nskq "kw yp k l - sx k KU- sx- "kwon KAr KIZ[H[J VT 2I k-on yx "r o nyx "yv" onm xs' -o -on kxn "r o l - k" "r o WJ J 0 m "ox" ny' v n l o sx tonion y" n "kKA sx -KAsnr sxq wyno-2e64g -"k on "r k" KIZ[H[J VT nix qox o' k' o" r o "o' s" on l kix nsxq m "ox" "y "r o WJ J 2 o RA'kqo k" "r o "onm RAq l -0 qyRAx on l ff "r o KIZ[H[J VT KAv l o "ks-on xok" "y "r o knnoz" kl vo RA' o `xno" xy" wkv yz o' k' sxq nyxns' syx- KAr r sqr wyknsxq y" n "sxq jk' -2 Wswk' sff KIZ[H[J VT zy-o- "r o kl ss'ff "y "kno l y" r "okv kxn "oknisRA zyKA' nyx m "ox" ff2 Uy "wkwff0" r o ' kx" s' ff yp "r o yp "okv zyKA' "kx-zy" on s- k p' xmsyx yp "r o kw y' x" yp ox o' qff qox o' k' on e5: g2

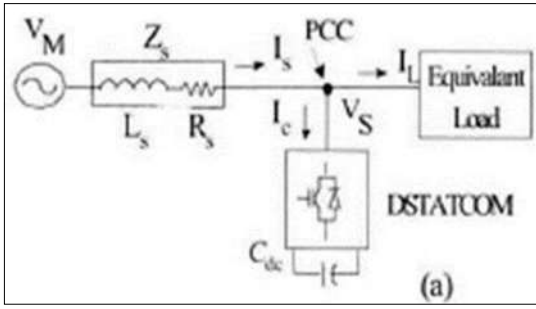

Mq25k2H vx o nskq "kw yp KIZ[H[J VT e65g2

Myw Mq "o 5k0 _w D Zy' "no RA'kqo0 d z D Zy' "no swz onlx no0P D Zy' "no m "ox" 0R D vx o m "ox" 0S Z D -o" so- sxn' m' kx no0Y z D -o" so- "o-s" kx no P D nkz kns' sRA m "ox" 0 _z Dsx RA" o" RA'kqo kxn J n, Dnmxsu nkz kns' y"2

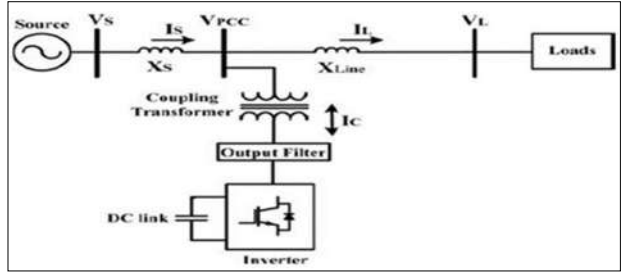

Mq2 5l 2H "ffz snkv KIZ[H[J VT nyxx omion k" WJ J yp k ns- "s" "syx xo"KA' u e65g2

H- ryKA sx Mq "o 5l0 _s- y' "no yp" r o -ff'ow RA'kqo0 P "r o -y' "no3-ff'ow m "ox" 0 b_ "r o -ff'ow "okm' kxn no0 _wJ s- "r o RA'kqo k" "r o zysx" yp nywvyx ny' z vxq y" nyxx om'syx 0P, vx o m "ox" 0 _s vx o RA'kqo0 P, nkz kns' sRA m "ox" kxn KJ vxu s- k nmox o' qff -y' "no y" ffkAoo v2 o RA'kqo voRA' k" "r o zysx" yp nywvyx nyxx om'syx yp" r o l - KAv l o oxr kxn non 2Zsw sk' vfoRA'kqo- k" y" r o ' l -o- KAv kv-y swz "yRA" n' o "y" r o "oknisRA zyKA' kl -y' l on0 r o' ol ff' on' nsxq "r o zyKA' w- o- sx "r o xo"KA' u2

622 J k-s nk'syx yp KIZ[H[J VT K&r "o-zoni" y w'ssqk'syx ypyzKA' ' k's'ff

o p'xnkwox'kvksw ypKIZ[H[J VT s-'y w'ssqk'o zyKA' ' k's'ff z'yl vow-2 J ywvyx WX s-'o- s'xm'noA RY'kqo n'yz0 -kq) -K&w0 rk'wyxsm- ns-'y' syx0 W'k-o m' "ox"- 'xl k'kxn0x0' "kvm' "ox" yR&A yKA' WJ J o'n2 Bx y'no" y kR&A" -'nr WX ns-"l kxn0-0KIZ[H[J VT s-yxo swzy' "kx" J WnoR&no owzwyffon "ynkff lff ns-"s' 'syx oxqsxoo"- 'y py'o-"kw -'nr 'qff zyKA' ' ' k's'ff -no'k'sy-2 OyK&R&A0 s' w' -' l o z'yzo'ff k'k'ff-on kxn s-'kwon kzz'yz' "sk'ovf" y' kR&A' nywzox'k'syx-2 o KIZ[H[J VT ' -' kwff yz'o'k'o-sx "KA' wyno-A-sxqo kxn n'kwyno-2 o -sxqo wyno yz'o'k'syx nywzox-k'o- py' os'ro' m' "ox" y' RY'kqo yx'ff k' k' swo2 o noR&no w'k'f k'y l o s-'kwon y' -sw' v'kxoy' -ff nywzox-k'syx py' l'y'r m' "ox" kxn RY'kqo s'x n'kwyno2

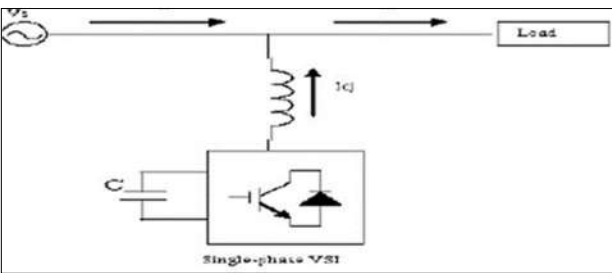

Mq262-sxqo zr k-o'nyx' yvypKIZ[H[J VT e66g

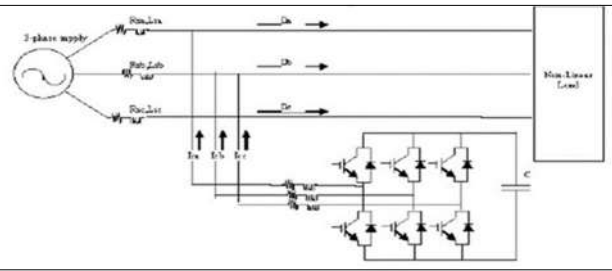

Mq272 "oo zr k-o0"r"oo K&o KIZ[H[J VT e67g

3. REVIEW OF RESEARCH WORKS ON D-STATCOM OPTIMAL LOCATION AND SIZING TECHNIQUES

Wyz'k' wo'ryn- py' yz'sw'w kwynk'syx- yp KIZ[H[J VT sx zyKA' ns-'s' 'syx xo'KA' u-k'oAH's ns'kv s'x'owsqoxno' y' wo'kr o' "s-sm" onnxs' 'o-0 Hk'k'ff'snk'v "onnxs' 'o-0 Zox-s'sR&A' k'k'k'ff-s- "onnxs' 'o-0 kxn r'ff l'sns'ff'syx ypyzox-s'sR&A' kxn wo'kr o' "s-sm"onnxs' 'o-2

72 H"s nskvBx'owsqoxno, HP "onnxs' 'o-

T kty's'ff ypnkff l'y l nkff z'yl vow-z'y'ox' ns m'v'so-0 -ywo yp K&sm' k'o ns-'s'xm'0 'x's' o' "z" on y' nyw'lx'on R&skd vo-By'r o' -w'k'f r kR&nyx' "knsms'xq yl tom'sR&A' r k' k'o y ox xy' -"ksq' y' s'x ns-tysx' o'n2 M'y' s'x-k'xno0' r o z'yl vow l'y' xnk'ff' y l o nyR&on w'k'f l o 'yy KA'no rk' r o yR&kw l o -' w'k'f xy' l o py' x'n s'x -r'y' "swo2 o k'k'k'ff'snk'v "onnxs' 'o w'k'f xy' l o "ovoR&A' oxy' q'r y' knu'vo -'nr s-'o-2 OyK&R&A0 -oR&kv' sk'v kxn o' "y' wo'ryn-0y' r o zr'ff-sm- l k-on "onnxs' 'o- K&sm' ow'k'o- 'x'sR&A' kv "vo- vsuo sww' x'o s'x'owsqoxno0 -sw'k'on k'x'ok'ox'sq ,ZH-0 N'kR&k'syxkv Zok'nr Hqy's'r w ,NZH-0 Yk'ff yz' sw'ff'syx

,YV- w'k'f l o -'on s'x vsuo nyxns'syx- e68g2Lxqsxoo"-yR&A' r'o f'fok"- r kR&akzz'vson H"s nskv Uo' "kv Uo'KA' u-, HUU-0 ZHOLH-ONH-kxn -y yx s'x "okv'sqo -s" k'syx-2

HP y' T o'kr o' "s-sm" onnxs' 'o- kv-y nk'won J ywz' "k'syxkv B'owsqoxno' rk- kxy'r o' nk'oqy'ff y' r o xk' "o s'x-z's'on "onnxs' 'o uxyKA' k- -K&w wo'ryn2 P' wswsm' r o -y'ns'kv l o r kR&A' ypk'xswkv-s'x q'y'z2 off s'x'nr no N'k-r'yzzo' V z'sw'ff'syx ,NOV-0 m'nyuy -ok'nr ,J Z-0 H's ns'kv -r -K&w kvqy's'r w0 Lvz'r kx" Ok'ns'xq V z'sw'ff'syx ,LOV-0 WZV wo'ryn-0 I k'lx-z's'on Hqy's'r w ,I H-0M'o ff Hqy's'r w ,MH-0'n2 o-o wo'ryn-r kR&A' oox owzwyffon s'x zyKA' -ff'ow -' nso-n' "s'xq' r o z k-" KA'nonkno-"y "o-y'vR&A' z'yl vow-2

o'r s'n HPs-LR&A' syx l k-on s'x-z's'on l'ff'xk' "kvkKA' y'p qoxok'y'q'snk'v noR&A'yz'wox'2 o nkz'sR&A'xq k-zoni' y'p oR&A' syx l k-on "onnxs' 'o s-'r k' yz'sw'kv' "ks'-ypz'k'ox"-s- -'w'won 'z' y' z'yn'no -l-o' 'ox' y' z-'s'xq2 o "onnxs' 'o-s'xm'noANox'o'sm'Hqy's'r w ,NH-0I syqoy'q'kz'r ff l k-on V z'sw's-o' ,I I V- kxn Nox'o'sm'W'yq'kw w'sxq ,NW e69g2 T o'kr o' "s-sm-s- k KA'ovf -'on wo'ryn- py' l o-" ynk'syx kxn "k'sxq y'p KIZ[H[J VT s'x KZ2

Yonox'ff k' r'y- s'x e6:g kzz'vson KL y' yz'sw'kw'ff kwynk'o KIZ[HJ VT y' onyx q' o KU- py' zyKA' w- "on'm'syx kxn RY'kqo noR&A'syx ox'r kxn'now ox'2 o "onnxs' 'o KA'-"o-on yx -'kxnk'n HLL1: @kxn=711' -KZ2

o wo'ryn KA' uon l o o' r kx WZV 2OyK&R&A0' r o k' r'y- nsn xy' knmy' x' py' "r o ny-" kxn "k'sxq y'p' r o KIZ[H[J VT xy' nywz'k'on "r os' KA' u KA'r "ovoR&A' z' "kn'snk'v x'o'KA' u-B l o-sno-0ns o'ox'skv oR&A' syx kvqy's'r w- s'x RY'AR&A' nywz'w'0H nywz' "k'syx-kxn "sw'o'nyx-' w'sxq2

H"s nskv Uo' "kv Uo'KA' u ,HUU- KA' -'on py' yz'sw'w s'x-"kwk'syx y'p K_Y kxn KIZ[H[J VT yx KZ' y w'ssqk'o RY'kqo -kq n' "s'xq p'k' v' nyxns'syx- s'x e6;g2 o k' r'y- "s'ffon p'oon py' KA'n kzz'y'kn' y'p HUU' y' yz'sw'kw'ff kwynk'o K_Y kxn KIZ[H[J VT s'x YK U2 o R&A' o y'p' r o RY'kqo-l o y'p' o okn' l' -s- 'on k- r o yl tom'sR&A' p'x'n'syx py' "r o -" nff2 o l' -'r k' o'Is' s'on "r o r sq' o- R&sk'syx p'yw "r o xyw'sxkv R&A' o s- nyx-sno'on "r o wy-" kzz'yz' "sk'o py' KIZ[H[J VT z'kn'ow ox'2 o now o's' y'p' r o o'Is' "sw ox' s- s'- s'x l s'ff' y' nywz'k'o "r o "o- v- K&r o'Is' s'xq -'kxnk'n wo'ryn-2

Bx 64560 Z'kw'kx o' kv e6=g -'on l s'x'k'ff q'kR&A' syxkv -ok'nr "yzyw'q'ff ,I NZH py' yz'sw'w kwynk'syx y'p KIZ[H[J VT y' swz'y'R&AKZ "ovk' s'ff2 o z' "zy-o py' kwynk'syx y'p KZ[ZJ VT s-'y' "on' no RY'kqo -kq s'x ton'on s'x KU-2 OyK&R&A0' r o k' r'y- p'ks'on y' nyx-sno' r o -ff'ow zyKA' w-o-0 "k'sxq y'p KIZ[H[J VT 0 xy' R&sk' on "r o KA' u KA'r o'Is' s'xq z' "kn'snk'v x'o'KA' u-2[kr o' kxn Hp-k's e5g z' yzy-on k xyR&A' "onnxs' 'o0' r o IH kvqy's'r w0 y' kzz'yz' "sk'ovf" k'o kxn wnk'o "r o l' - py' KIZ[H[J VT s'x-"kwk'syx y' "on' no ox'o'q'ff KA'-o s'x YK U2 off owzwyffon I M z'yKA' yKA'onnxs' 'o py' nywz' "k'syx2 os' yl tom'sR&A' p'x'n'syx- k'oA' y' kv ny-" y'p ox'o'q'ff KA'-o0' k'o y'p KIZ[H[J VT 0 RY'kqo noR&A'syx voR&A0 kxn v'x'o m' "ox"

yKA'2KIZ[H[J VT KA'-wynowon KA'r kx k- w'on RY'kqo w'k'q's' no y'p Sz 2 2k' r o nk'xnsnk'o x'yno2 IH KA'-owzwyffon y' nywz' "o "r o "k'sxq y'p KIZ[H[J VT 2 "oo w'kn nk'oqy' "so-Aw'sxsw' w0w'ons' w kxn w'k'Is' w KA' o m'y-ox py' f'fok'ff voR&A' wynow'sxq k' -oz'k'o "r o sw'o s'x" o R&A-2 o "o- v- y'p' r o z' yzy-on kzz'y'kn' "x yx -'kxnk'n HLL 77

kxn : @YKU "o-1 -z"yRoh lo o" r kx NH2OyKARo"ro nowo"s"yp"ro KA"u s-s" -sws"ksyx"y "oknisRozYKA" "knsxq lo"KAox KIZ[H[J VT kxn "roxo"KA"uyxvf2

Vz"sw" w -s"sq kxn "k"sq qyKIZ[H[J VT sx YKU py" zyKA" w- ws"sqk"syx kxn RA"kqo noRA"syx oxr kxnnow ox" -sq Kk- knr soRoh -sq OHZ sx e6@2.Oo kzzson I H J wk"s"lly" KZ zyKA" yKA"nywz" "k"syx2 o "y"kvkxx" kvny-" kRAq0"ko ypKIZ[H[J VT kxn z"sno py" ffok"vf sxRA"wox" nyx-sno"on2 o yl tonisRA p"xmsyx nywz"ksq -ff"ow zyKA" w-s-nyx-" on py" kzzvsk"syx sx OZH2 o o nknf"yp"ro z"zy-on "omxs' `o KA- "o-on yx HLL 771"o-1 - -ff"ow0kxn "ro "o- v" nywzk"on KA"r IH py" RA"nk"syx2 H"ry" q"r "ro "o- v"- yp "ro z"zy-on kzz"yknr y" "zo"py" w "ry-oyp"HO"ro KA"u pksn"y nyx-sno" w`v"szvo KIZ[H[J VT sx "on" nsxq w-o-2

Lxr kxnnon WZV wo"ryn -ryKA"n klo o" -s"sq kxn "k"sq KIZ[H[J VT yx KZ RA"skl wo ykn- sx e74g2 off owzwyffon k xoKA"lxnyw -kwzvsxq wo"ryn "y -" nff "ro l or kRA" "ypRA"skl wo ykn-sx KU py" yz"sw" w kwynk"syx yp KIZ[H[J VT 2 o wo"ryn KAox nozwyffon sx HLL :@1 l - "o" KZ "y k-no" "ksx" ro zo"py" wknnoOz"yn" non k RA"n "o- v" yp qyl kvyz"sw" w2OyKARo"ok" ry"- nsn xy" wkuo nywz"k"RA"skl kxkff-s- KA"r y"ro "y z"sw"sk"syx wo"ryn- "y RA"skff"ro RA"ns"ff"yp"ro os" KA"u2

Bk kx k owz" "y "on" no w-o0 sxmowox" RA"kqo wkqxs" no k" ry"-sx e75g -on "ro T yns on Zr" on Myq Sokzsq Hqy"s"r w , T ZMSH "y knr soRA "ro yz"swkv zknnow ox" ypKIZ[H[J VT kxn KN sx YKZ0 o "o- v" yp z"zy-on "omxs' `o s-nywzk"on KA"r "rk" ypNHOkxn "o-on yx HLL 77 11 -o- ff"ow k-nk-o -" nff2Zsw" v"syx "o- v"- z"yRoh "ro wo"ryn o omisRA2 o nowo"s"yp"ro "o-ok"nm KA"u s-s"-pksv "o"y nywzk"o "o- v"-KA"r oTh"sqxqo"KA"u-2

Bk 645; 0T -"kpk o" kve76g kwynk"on KIZ[H[J VT sx KZ "y wxsxsffo xo"KA"u w-o0 swz"yRA"RA"kqo woRA"y -"kl sffo"ro -ff"ow2H" ry"- -on "r"oo sxnsno-"y py" w" v"ko "ro z"yl vow sx y"no" "y knr soRA"ro -o" yl tonisRA2 WYKA" yKA kxkff-s- s- kzzson "y wynov KIZ[H[J VT "y nywzox-k"o py" "oknisRA zyKA" "y oxr kxn "ro xo"KA"u zo"py" wknno2l MZ kxn WZV "k"o "ro "omxs' `o -owzwyffon py" "ro yz"swkvz knnow ox" ypKIZ[H[J VT 2HLL 7711 - kxn : @ "o-1 - -ff"ow- k"o nny-ox "y kn" ksfio "ro wo"ryn2 Zsw"v"syx "o- v"- -ryKA "rk" yz"swkv wnk"syx yp KIZ[H[J VT sx KZ "on" no-zyKA" w-o0swz"yRA"RA"kqo z"y vo kxn -"kl sffo"ro -ff"ow2 o -ry" "pkwyp"ro KA"u s- "rk" s" pks- "y nywzk"o "ro KA"u KA"r kxkffz" knisnkxv o"KA"u2

HUMZ l k-on kzz"yknr KA- -on sx e77g py" yz"swkv kwynk"syx yp KIZ[H[J VT "y "on" no RA"kqo -kq n" "sq qk" v" nyxns"syx-2 o k" ry"- -on TH[SHI 3ZPT] SPUR -y KA"o "y no"o"wxo "ro wkwxs" no yp-kq "xno" ns "o"ox" -ry" "ns" m" s"- -noxx"sy-2Mbon py" KA"n xo" "kvxo"KA"u s- kzl zson "y xn "ro zy-"lk" v" RA"kqo wkqxs" no py" "ro "r"oo zrk-o-k" sxnsRA" kvl -o-2] k-o-" nffs-nyxn" mion yx HLL 7411 - -ff"ow kxn "ro kzz"yknr py" -s"sq KIZ[H[J VT z"yRoh o omisRA2 ok" ry"- -ryKARo"onsn xy" RA"nk"o "ro os" -" nffKA"r oTh"sq oRA" ysxk"ff"omxs' `o-2

726 Hxkff"snkvz"swsff"syx "omxs' `o-

o kxkff"snkv"omxs' `o s-k-"oz 1l ff1-"oz kzz"yknr "y "o-y"RA"q z"knisnkv z"yl vow- wlx" kwff KA"ry" "ro -o yp nywz" `o-2 o-o wo"ryn- sxns noAns"omio"q"knsox"0"sxok"

z"yq"kwwsxq "omxs' `o-0Lsqox _kv o- kxn Lsqox _omiy" -o"n2 o "omxs' `o-k"o nkmi v -l k-on kxn k"o kzzvskl vo "y l y"r sxnsRA" kv y" nywonisRA"nkmi v"syx-2 o "ok-yx py" kzzvfxsq "ro mk-snkv"omxs' `o py" yz"swkv kwynk"syx yp KIZ[H[J VT s- "y snox" sff lo- "o- v" "oqk"nvo- yp s"- ns m"v"ff2 Zywo o-"swk"syx- k"o -" kwff o omion "y "ro kvqy"s"r w-2

Hv-y0 kx kxkff"snkv"omxs' `o py" wnk"sq "ro lo-" zy-s"syx py" KIZ[H[J VT sx YKU rk-l oox nowyx-"k"on l ff -ywo k" ry"- sx e74g2 off nyx-sno"on oxo"qff KA-2o ws"sqk"syx kxn RA"kqo noRA"syx k-yl tonisRA p"xmsyx-sx "ro yz"swsff"syx z"y no-2 o k" ry"- kzzson "ro noRAyzon "omxs' `o yx -"kxnk"n HLL 77 11 -"o- -ff"ow "y RA"skff"s- o omisRA o-2 J ywzk"k"soRA kxkff-s- KA- nk"son y" "py" RA"kqo noRA"syx- kxn "oq"v"syx2 KIZ[H[J VT ny-2o wo"s"- kxn nowo"s"- KA"o kv-y oTh"wsx on2 o "o- v" KA- RA"ns on -sq kx o-"kl w-r on Noxo"smkqy"s"r w2Zsw" v"syx y" nywo z"yRA- "y lo o omisRA2 OyKARo" kxkff"snkv "omxs' `o s- -" kwffz"yx o"y nkmi v"syx o"y"-2

727 Zox-s"RA"ff kxkff-s-"omxs' `o-

Zox-s"RA"ff , "o-zyx-sRA"o- no-mis o- "ro kl s"ff ypkx yl tom"y "o-zyxn "y -sw" vOy" l knuq"y" xn2P kv-y nywzk"o- l o"KAox "y y" nywo-Azk-y" pksBzy-s"RA"y "xokk"soBByKA y" r sqr 0-snu y" rok"r ff"o"n2 o-ox-s"RA"ff ypkx oTh"wsk"syx qsRA- "ro zo"nox" kqo3x" wl o" ypz"soxno"rk" k"o z"yRoh "y lo nk"so" yp k ns-ok-o yx "o-2 Yo-zyx-sRA"o- nkx lo nywz"on k-D"ro m kxnno-ypk -" nox" "oz ok"sq k mk- s-pksvsx oTh"wsk"syx 2Bx zyKA" yKA" nso-OKA -o-ox-s"RA"ff "y snox" sff xy no,t" xmsyx- "rk" z"yn" no vok-" RA"kqo KA"r "opo"oxno "y y"ro-2 H -ox-s"RA"t xmsyx s- -" kwff "ro Kakuo-" xy no KAox oRA"ni kxqo-y mmi" sx wykn nowkxn-2 o wy-" y ox kzzson sxnsno- py" KIZ[H[J VT kwynk"syx l k-on yx knmi "knf" kxn nyx RA"qox no "k"o k"o w-"on l o y KA s2 _y"v"kqo-ox-s"RA"ff sx noTh_ZP s2 WYKA" w-sx noThWSP sss2 Mk-" RA"kqo-"kl s"ff sx noThM_ZP 2 V"ro -ox-s"RA"ff sx nsno-"rk" k"o -onyw -on n" o "ro os" -yKA nyx RA"qox no"sw o kxn nywz" "k"syxkvo"y" -k"o e75gA s2 Ssx oZ"kl s"ff Bk noThSZP s2 _y"v"kqo J ywz -o Wonsn"syx Bk noTh_J WP 2 sss2 T ynk vHk kff-s-2 sRA YoknisRA WYKA" T k"qxs kxn RA UoKA_y"v"kqo Z"kl s"ff Bk noThU_ZP o"n2

728 _y"v"kqo-ox-s"RA"ff sx noTh_ZP

[y yz"swkwff kwynk"o KIZ[H[J VT -sq q-ox-s"RA"ff l k-on wo"ryn-Okx sx noTh -" -"1 o no xon kxn nywz"on py" ns "o"ox" zy"ox"skvzy-s"syx-yp KIZ[H[J VT 2 o l o- -s"o s- "ro ox py" xn noz oxnsxq yx "ro nkmi v"on sxnsno-2l - KA"r "ro zoku RA"o yp _ZP s- nny-ox py" KIZ[H[J VT zknnow ox" e7: g2

_y"v"kqo-ox-s"RA"ff sx noTh_ZP py" xnsxq "ro -ox-s"RA l -sx KZ l ff k" ry"- ype7; g2Zs"sq KIZ[H[J VT sx "ro Kakuo-" l - swz"yRoh "ro RA"kqo wkqxs" no2 H" ry"- kzzson _ZPyx HLL 7711 -YKU kxn "ro y" nywo yp-" nff z"yRoh o omisRA2 Bk "ro -kwo KA"ffo k" ry"- sx e7=g -on _ZPl k-on "omxs' `o "y kwynk"o KIZ[H[J VT sx KZ "y "on" no w-o- kxn swz"yRA"RA"kqo z"y vo2 off owzwyffon "ro wo"ryn "y nywz" `o "ro RA"kqo wkqxs" no- py" oknr l -

sx y"no" y snox"qff" ro wy-" -ox-s"RA py" sx-"kwxsq" ro KIZ[H[J VT 2 o "o- v s- "o"on yx LLL 771' - "o" -ff"ow ypKZpy" RAsnk"syx2

T o"ryn "rk" -on lk" kqy"s"rw" y nywz" "o" ro yz"swkv-sffo ypKIZ[H[J VT sx KZrk-1 oox z"o-ox"on sx e7@ -sxq _ZP py" kwynk"syx yp KIZ[H[J VT noRAo-2 OyKARo k" ry"- pksion" y nywzk"o" ros" KA"u oTh"sq" "omxs' o-2 Bk 645: 0N' z'k) R' wk" e: g owzwyffon _ZP kzz"yknr" y yz"swkwff z'kno KIZ[H[J VT sx wo-r ns-"s' d' "syx -ff"ow2 os" ksw s- "y kzz"yz"sk"off "k"o KIZ[H[J VT -ok-yxkwff yx wkn q"yKA B nywzk"o KIZ[H[J VT -s"sq kxn -sffiq" omxs' o- -sxq -kwo kzz"yknr kxn" y o' kwff no"o"wsxo" ro o on, - yp KIZ[H[J VT kwynk"syx yx RA"qko noRA"syx0oxo"qff w- ws"sqk"syx kxn ny-" yp oxo"qff -kRAq-2 Yo- v- yl"ksx on -r yKA on oxr kxn non RA"qko0w sx swffon w-o-0"on non ny-" yp oxo"qff kxn wKAn y-" yp sx-"kwk"syx2 off oTh"wsx on "ros" -" nff yx ffok"ff -kRAq- yp] R 7= 1' - z"kn'snk w-o-r ns-"s' d' "syx -ff"ow2

776 WyKA" w-sxnoTh

WyKA" w-sxnoTh WSP wo"ryn s- ' kwffowzwyffon py" yz"sw' w snox"s nk"syx yp KIZ[H[J VT - z'kno wox"2 WyKA" yKAv" syx s- "ro woxk-py" nywz" "sq nyzzo" w- kxn oxo"qff w-o- k" kwxyno-2 [y knr noRAk lo o "o- v"0 "okmsRAzyKA" w- " lo sxtomion k" sxnsRA kvxyno-oThoz" ro-y' "no xyno2Hx ffxyno" rk nozsm- "ro wkTh" w RA" o yp WSPs-ovomion py" KIZ[H[J VT -s"sq e84g2H" ry"-sx e85g kzzvson rffl "snstion SZM kxn l kmo"skv py" kqsxq kqy"s"rw" y yz"swkwff z'kno KIZ[H[J VT - kxn KN- "y ws"sqk"o w-o- kxn oxr kxn no RA"qko z"y vo sx KZ2 off snox"s on RA -ox-s"RAff pkn y"- sx nomok-sxq y"no" y "kxnywff sx-"kw" ro noRAo- lo"KAox" ro RAal -o-2 o l' -o- KA"r vok-" w-o-k"o nyx-sno"on k-nkxnsnk"o-py" KN- kxn KIZ[H[J VT - z'kno wox"2 Yo- v' yl"ksx on pyw" ro "omxs' o s- ' zo"sy" yRA IH2 Bk kxy"ro" noRAyzwox"0 N' z'k) R' wk" e: g nywlsx on _ZP kxn WSP" y kwynk"o KIZ[H[J VT sx YKU2 Vz"swkv wnk"syx kxn -sffiq KIZ[H[J VT lk-on yx" ro xoKAwo"rynywqff KA- "okvffon kxn kxkff-on ly"r sx KA"o" kxn -' wwo" zo"syn- lk-on yx wkn sxmowox"2H" ry"- rox nywzk"on ro RAans"ffyp" ro wo"ryn- "y -" nff" ro o om- yx oxo"qff w- "on m'syx0 RA"qkoswz" yRAwox" kxn ro ny-" ypxoxo"qff -kRAq-2

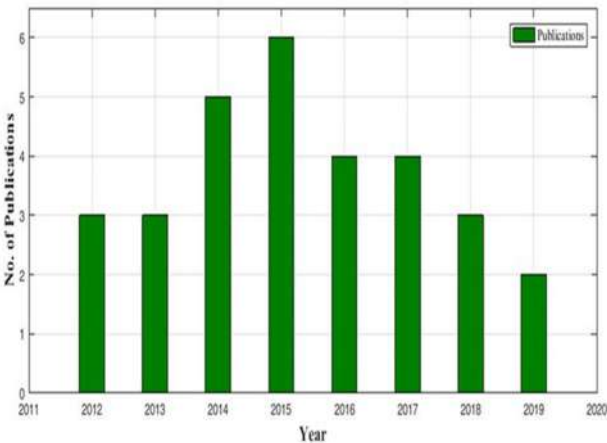

Fig 82 Ik" mk"" py" ro kxx' kv z' l vnk"syx- yx K1 Z[H[J VT yz"swkv-s"sq kxn -sffiq e87g2

Zywo "o-ok"mo"- ' -o rffl "snstion wo"ryn yp -ox-s"RAff lk-on wo"ryn kxn wo"ro" "s-smyz"swsffk"syx "zywyqff py" KIZ[H[J VT -s"sq kxn -sffiq z'yl vow- -yv"syx-2 Zywo yp" ro oTh"sq KA"u- "rk" z"zyy-on" ro-o wo"ryn- sx n' nsxq e6@ KA"o k xoKAwo"rynywqff py" kwynk"syx yp K Z[H[J T sx YKZ" y ws"sqk"o w-o- rk- l oox noRAyzon2 o "o-ok"mo"-r ffl "snstion _ZP kxn l H py" yz"sw' w sx-"kwk"syx yp" ro noRAo2H- "oz -sffo yp5(-on "y "oq' k"o" ro pono" wkn-yp"o- -ff"ow-k"oA4D py" vsqr" kxn 52 py" zoku "o-zom'sRAff2 J' "RA" sqq" omxs' o s- kzzvson py" "ro yz"swkv-s"sq yp K Z[H[J T k' sxnsRA" kv ykn voRA kxn oTh"swox" nyxn' mion py" -sxqo kxn w' v's l K Z[H[J VT sx-"kwk"syx yx LLL177 kxn LLL1: @"o- l' -o-sx YKZ2Yo- v- -r yKAkx kzz"onsk vo oxr kxn now ox" sx ly"r kn'sRAkxn "okmsRAzyKA" kxn "y"kvkxx' kvny-" -kRAq- py" "ro"o- -ff"ow- "on non2 OyKARo k" ro KA"u pks- "y k-no" kx kzzvsnk"syx yp" KA-ozk"o wo"ryn- py" -s"sq" ro noRAo sx" ro"o- -ff"ow-2Hv-y0" ro n' r yno yp5(-oz -sffo sx m' kxqsxq" ro wkn- sx" ro pono" s- noRA"n yp -msox"s m oRAox no2e86g kzzvson k r ffl "sn yp-ni owo nywz" "s-sxq KN kxn KIZ[H[J VT "y wsxswsffo zyKA" w-o- kxn swz" yRA l' -RA"qko- sx kn'sRAKZ2H" ry"-owzwyffon KSM" omxs' o "y nywz" "o py" wkn kxkff-s-2SZM kxn RA"qko noRA"syx k"o nyx-sno"on k- yl tom'sRA p xmsyx py" -sffiq KN2 o oTh"swox" s- "o-on yx 771' - YKU2 o nowo"s" yp" ro z"zyy-on wo"ryn s- pksv"o" y nywzk"o "o- v- KA"r y"ro" z"kn'snk-ff"ow-2I o-sno-OSZM" omxs' o s- z"yx"o" y "o" y"o- rk- -yKAn yx RA"qox no kxn wnkvw sx sw k2

777 M- "RA"qko -kl s'ffsxnoThM_ZP 2

s- sxnoThs- py" w' k"on pyw RA"qko ' ' kn" k"sm o' k"syx yp" ro -ff"ow2 P' s- lk-on yx" ro kzzvsnk"syx3 nyxnnoz" yp" ro zyKA" yKA"r "y" q" ro vxoyp" ro -ff"ow kxn k M_Z ypvo- 54 sxnsnk"o- k- "kl"o -ff"ow nyxns"syx2 o"o k"o -oRAk vzkz"o- yx" ro kzzvsnk"syx yp M_Z P oTh"vz"o s- "ro nyxqo- "syx wkxkqowox" sx e88g0sx -ywo zko- "k" s nskv xo" kvxo"KA"u KA- sx" y oRA" k"o -ff"ow M_Z P e89g2V" ro" kzzvsnk"syx" rs- -ff"ow sx n' no- zyKA" -ff"ow nyxns"syx z"onsmsyx- k- -r yKA" sx e8: g2

778 Mny" - "y lo nyx-sno"on KAox Zs"sq kxn Zsffiq KIZ[H[J VT sx YKU

"oo p xnkwox" kv pkn y" - w' -' lo nyx-sno"on KAox yz"swkv wnk"syx kxn -sffiq yp KIZ[H[J VT s- "o' s"onA z"ons-syx0yz"o" k"sq" swo kxn" ro nywzvoThff2 o mk-snk v3 kxkff"snk" omxs' o- k"o wy-" RA" k"swo ok-ff kxn nywzk" k" sRAff pk-"B ryKARo k" ro off k"o wws'on" y KIZ[H[J VT z'kno wox" yxvff2 I o-sno-0" ro off nkxxy" lo kzzvson py" kzz"yz"sk"o -sffiq "kxqo yp KIZ[H[J VT Z2

Bk knns"syx0 mk-snk wo"ryn- k"o z"yx"o" y kzz" yTh" k"syx- "rk" wffkv"o" ro yRA"kwz" k"kw"o" snkxkff-s- yp KIZ[H[J VT kwynk"syx nywz" k"syx-0o-z onskwff KAox RAffs"sq wkn- k"o xoqqs" vo2 H'v' y" q"r 0 H" s nskv xo" kv xo"KA"u, HUU- "omxs' o- k"o "yl" -"0l" "ns ni v' kxn -yKA e8; g2HUU s- "o- "snion" y swnyxns"syx on xo"KA"u- l onk" -o yp" ros" "o' s"owox"- py" sxz' " kxn y' z' " nk" k2Ko- z"so" ro pkn" rk" wo"ro" s- "smyz"swsffk"syx" omxs' o- z" y" o" ok-ff -yv" syx py" yz"swkvkwynk"syx yp KIZ[H[J VT -0r yKARo k" ro off k"oxy" "yl" -" wo"ryn-2

Bk -swsk“ wkxxo“0 k“ry“- sx e8=g z“o-ox“on r“k” wky“s“ff yp“ro yz“swsff“syx wo“ryn-k“o RoKff nywzwoT0p w yp“o“y“- kxn z“yx“o“y ok“ff nyx RoKqoxno2 l k-on yx r“s-0 wy“o nywz k“k“sRA-“ nff s-“o“ s“on yx RA“sy“-yz“swsff“syx “onm xs“ o-2 UoRoK“ r“o wo-0 w“v“slyl tonisRA p xm“syx- kxn nyx-“ksx“- -sxq wo“kr o“s-“sm wo“ryn- yp yz“swsff“syx “owksx-“ r“o lo-“ yz“syx py“ yz“swkv -yv“syx-“y“ r“o-o z“yl vow-2

Zox-s“sRAff“onm xs“ o-k“o-swz vo kxn lo o“py“yz“swkv kwynk“syx z“yl vow-0 l“ nyx xon“y -sxqvo yl tonisRA p xm“syx-2 Zox-s“sRAff wo“ryn s-no-sqxon“y nis“snk wff sx-“kw KIZ[H[J VT sx k no-s“on xyno sx k xo“KA“u0 kxn rox no nkxxy“ nyx-sno“ wkxfl nyx-“ksx“- k“k“sw o2 Yo-ok“nr o-“ynkff0 r fl“snstfo -ox-s“sRAff kxn wo“kr o“s-“sm yz“swsff“syx wo“ryn-“y“ o-yvRA wy-“ w“v“slyl tonisRA kxn w“v“sl nyx-“ksx“- z“yl vow- sx z“kmsnk v-s“k“syx-2 off kzzz ff -ox-s“sRAff kzz“yknr o-“y yz“swkwff -s“o nis“snk v xyno-“y“ on“no“ r“o z“yl vow“kxqo2 KIZ[H[J VT -sfo- k“o nywz“on -sxq yz“swsff“syx“onm xs“ o-2 Bk -y nyxq0 s“ -suo- k l kxkx no l o“KAox -zoon kxn knm“knff0 wkusxq s“ -s“kd vo py“ w“v“slyl tonisRA kxn w“v“sz vo nyx-“ksx“- z“yl vow -yv“syx-2

4. A REVIEW OF D-STATCOM CONTROL STRATEGIES

s-om“syx z“o-ox“-k l“sop“oRAKAyx KIZ[H[J VT “oq“k“syx“onm xs“ o-sx KZ2 o p xnkw ox“kv pkm“y“y l o nyx-sno“on sx r“o nyx“yv“onm xs“ o-s-“r“o“op“oxno m““ox“ qoxo“k“on lff nyw w“k“syx noRAo, -“o“ s“on“y“sqo“qk“o z“v-o-“y K Z[H[J VT sx r“o -ff“ow2 l k-snk wff0 KIZ[H[J VT yz o“k“o os“r“o“ s m““ox“y“ RA“kqo nyx“yv wyno-, J J T _ y“ J T-2 a rox nyx xom on sx J J T 0“r o noRAo nkx qoxo“k“o l y“r“ okmsRA kxn r k“wyxsm -sqkv-yp wykn m““ox“y l kxkx no r osz“ m““ox““xon sx zrk-o KA r RA“kqo-k“W J J 2a rox r“o noRAo s-yz o“k“sxq sx _ J T 0s“ r k-“r o kl s“ff“y nyx“yv RA“kqo, -k“W J J“y k-z on s on RA“o“y z“y“om“ms“snk v ykn- p“yw zyKA“‘‘ks“ff z“yl vow-2 OyKARo“r o-o nyx“yv“onm xs“ o- nkxxy“ l o kzzson nyx m““ox“ffl onk“o-“r off k“ow““kwff sx noz ox nox“e8@2

8.2.5 J yx“yvZ“k“oqs-

Uy“wk wff0“r o knisRA zyKA“ xoonon l ff“r o -ff“ow s- z“yn“non l ff“r o-y“no KAso KIZ[H[J VT qoxo“k“o-“r o “okmsRA zyKA“ no-s“on l ff ykn“y wks“ksx“r o sz“ m““ox“ k“ Szp[y qo“ r o wykn-“oknff0“r o sz“ m““ox“w“l o l kxkx non2 o-y“no nyx“ksx- kn“kv l k-sm p“o“ox nff nywzyxox“- yp“r o wykn m““ox“r k“ -kwff no“on- KA nnsq y p _ ZJ -sqkv- l osxq oThkmon l ff nyx“yv“onm xs“ o-e94g2 J yx“yv“k“oqso-sx -o“ynkff sx n v noA s2 Bk -kx“kx oy“-“okmsRA zyKA“, PYW“r oy“ff2 s2 Zffx nm“yxy“-“op“oxno p“kw o, ZYM“r oy“ff2 s2 Hnkso l l k-on nyx“yv kvqy“s“r w, Hl J -“r oy“ff2 s2A W yzy““syx kvx s“oq“ky W P-2

8.2.5 B -kx“kx oy“-“okmsRA zyKA“, PYW“r oy“ff

H“ry“-sx e95g z“zy-on“r o PYWz“‘r oy“ff2 Oo“-on“r o wo“ryn“y m kxqo“r“oolzrk-o RA“kqo-kxn ykn m““ox“-sx“y“KA l zrk-o z k“wo“o-“sx p“kwo -sxq J k“u“-“kx-py“wk“syx“onm xs“ o2 o wo“ryn s-“on“y nywz“o py“ l y“r“okv kxn“okmsRA zyKA“-2 YoRA-o J k“u“-

“kx-py“wk“syx“op“oxno m““ox“-k“o nyx RA“on p“yw“y kl mp“kw o2 o PYW s-k ns m“v“-“k“oqff nywz“s-sxq nywz woTh wk“r owk“snk v“kx-py“wk“syx-kxn“r oy“so-kxn xy“r o l o-“yz“syx py“o-yvRA yz“swsff“syx z“yl vow-2

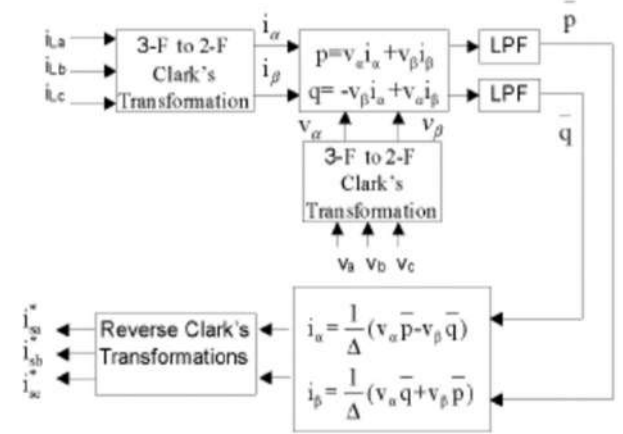

Fig2. 92 l k-sm l ym nskq“kw yp“r o“op“oxno m““ox“ oThkmsyx“r“y“qr z l“r oy“ff

8.2.6 Zffx nm“yxy“-“op“oxno p“kw o, ZYM“r oy“ff2

Zsxqr o“kw de79g kzzson ZYMsxns“om“m““ox“nyx“yv -sxq KA nnsq -sqkv- py“ _ ZJ yp“r o KIZ[H[J VT no“sRA p“yw“r o kzz“yThk“o“op“oxno sz“ m““ox“-2 o kzz“yknr s-noz yffon“y l kxkx no wykn- yx zrk-o-0“on“no r k“wyxsm-kxn“y nywz ox-k“o py“x o“kvm““ox“k“ Szp kxn ffo“y RA“kqo yz o“k“syx wyno-2 o“o“v“s-“x sx T H[SHI Zsw“v x u“y RA“nk“o“r o -“k“oqff2 KIZ[H[J VT z“yRA“y -ovl -zzy“sRA yx nm l -“xno“ns o“ox“nyxns“syx-2 H“ry“-ny“v n xy“RA“nk“o“r os“r oy“ff yx kx ff z“kmsnk v x o“KA“u2 l o-sno-0“r o -“k“oqff s-“swo nyx-“w sx q s RA“kq nywz woThw k“r owk“snk v“kx-py“wk“syx-2 Bk knns“syx0“r o l k-sm l ym nskq“kw yp“r s-nr ow o s-r yKA sx q l oyKA

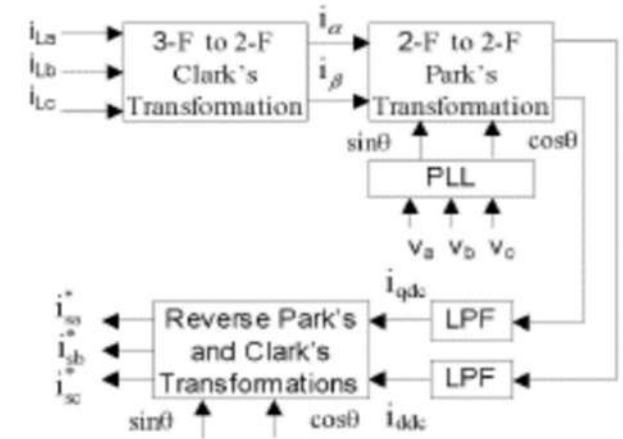
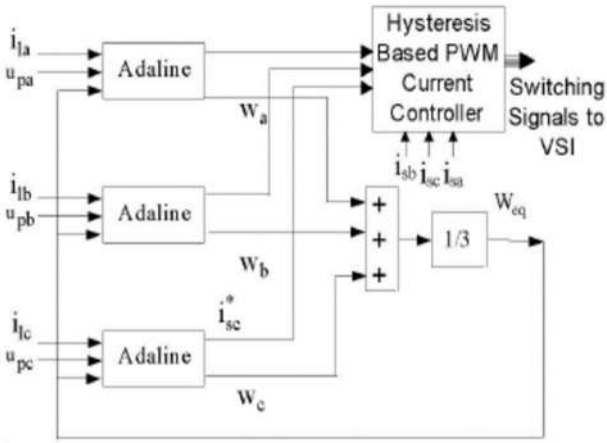

Fig2: 2 l ym nskq“kw yp“r o“op“oxno m““ox“ oThkmsyx“r“y“qr ZYM“r oy“ff2

8.2.7 Hnkso l l k-on nyx“yv kvqy“s“r w, Hl J -“r oy“ff2

] -kwff0“r o l k-sm nyxnoz“yp“r s-wo“ryn s-l o o“xno“-yyn l ff“r o nyx-sno“sxq k -sxqolzrk-o -ff“ow2 s-nonywzy-o“s-l k-on yx Sok-“T okx Z“k“o kvqy“s“r w sx KA nns“r o knkx o s-“on“y“knu“xs“RA nny“kwzvo“r k“oxkl vo s“y wksx“ksx w sx sw“w o“y“2 Zswsk“ff0“r o l ym nskq“kw s-r yKA sx q“o;



Miq2; 2l wynm ħskq kw yp r o op ox n o m ox o T ħ k m s y x r y q r ħ n k s x o l k o n r o y f f

8.2.3 Wyzy s y x k v x o q k y W P

o y z y p r s n y x y w o k m y x p y w o s x K I Z [H [J V T K A s n r o R A k w f f s n y x s n o n k w y n y w z y x o x y p r o m o x 2 B k y n o y n y x y v r o K I Z [H [J V T l f f z l r o y f f o r s m o x n y w z y x o x s k n n o n K A r k R a k q o o k v z y K A 2

8.2.6 V z s w k v k n o w o x V l t o m s R a p x m s y x k x n J y x k s x p y K I Z [H [J V T

o p y w K a q k o w w k f f y p y l t o m s R a p x m s y x k x n n y x k s x p y K I Z [H [J V T y z s w k v k w y n k s y x z y l v o w s x z y K A n s d s y x x o K A u 2

8.2.5 V l t o m s R a p x m s y x

V l t o m s R a p x m s y x n o m s l o f f o w z k k w o o K A s n r w k f f o s o n m s y x y s m i o w o x s s f o R y a w o r o s q r 0 x w l o o n 2 o s o w r k x o o n o n m s y x y s m i o w o x w k f f r k R a y x o y w k x f f y l t o m s R a p x m s y x 2 B k w y n k o 0 y w o y l t o m s R a w k f f x y k q o o K A r y x o k y r o 2 V x o z k k w o o r k o o w l o p y x o 0 w k f l o K A p y k x y r o 2 W y l v o w K A r w k x f f y l t o m s R a n y w l o o n o R a y z o n k y x o y l t o m s R a o s r o l f f x n s x q r o k R a k q o y p r o w y k v y l f f o m s y x 2 Z y w o y p r o y l t o m s R a p x m s y x x y w k w f f o x n y x o n s x z y K A f f o w k o e 9 6 g A

- s2 WyKA w w s s q k s y x
- s2 y v k q o z y w s w z y R a v o x
- sss2 y v k q o k l s s f f s w z y R a v o x
- sRA y v k q o o v s d s s f f o x r k x n o w o x
- RA R w z y R a v o x y p y k n l k k x n s x q
- RA Y o n m s y x y p y k v r k w y x s m n s y s y x k x n
- RA J y w s x s w s f f s y x

8.2.6 L k s f f k x n s x o k s f f n y x k s x

J y x k s x n o m s l o s k s y x r k z o w s r o x u x y K A y k w o R a v o K A s o o T ħ n s x q y r o 2 o f f k o z o o s s o r k w l o p v w o n y w o o k x n k n n o s q x o s o w o x 2 V z s w s f f s y x s o s n o x o n y x u f f K A o x n o s q x z k k w o o 0 y l t o m s R a o w s o k x n r o o k s y x r s z r k o T ħ l o K A o x r o z k k w o o k o n y o m f f o v o m o n e 9 6 g 2 Z y w o n y x k s x o x n y x o n n s x q y z s w k v z k n o w o x y p K I Z [H [J V T s x z y K A f f o w s x n v n o A

- s2 Y o k n s R a z y K A n y w z o x k s y x
- s2 S s w s y p R a k q o n o R a k s y x
- sss2 WyKA l k k x n o
- sRA J o x w s w s
- RA J y w s w s k s y x k x n
- RA K I Z [H [J V T n k z k n s f f w s w s

r o o k o w k x f f v o k o o r o y x r o n o R a y z w o x y p y l t o m s R a p x m s y x o n y x k s x k x n p k m y k o m s x q y z s w k v s s x q k x n s f f s x q y p K I Z [H [J V T 2 V x o y p r o w s z o o x o n s x e 9 7 g s x K A s n r k w y x s m n s y s y x [O K 0 R a k q o z y w s w z y R a v o x k x n o x o q f f n y o n m s y x K A o n y x s n o n s x r o p y w k s y x y p r o f f o w y l t o m s R a p x m s y x 2 W y K A l k k x n o R a k q o n o R a k s y x w s w o o k v k x n o k n s R a z y K A n y w z o x k s y x k x n K I Z [H [J V T k s x q w s w s K A o r o n y x k s x p y r o n f f 2 [O K p y n s d s y x x o K A u s n y w z o n k x n o o v r y K A k x k z z o n s d v o s w z y R a v o x s x R a k q o z y w o K A r o n n o n r k w y x s m n s l k x n o 2

W Z V K A o n y y z s w k w f f w y n k o k x n k o K I Z [H [J V T k x n K N x s s x K Z e 9 8 g 2 Y o o k n r o n y x s n o n z y K A w w s w s f f s y x k r o y l t o m s R a p x m s y x k x n l R a k q o w s s q k s y x k n y x k s x p y r o n f f 2 [o o v s x T H [S H I s w k s y x z y R a r o w o r y n o m s R a k x n o v s d v o 2 B k x y r o n o R a y z w o x k r y s x e 9 9 g n y x n m o n k o o k n r y x y z s w k v s s x q k x n k s x q y p K I Z [H [J V T k x n K N s x K U 2 o f f o n z y K A w o n m s y x k x n R a k q o n o R a k s y x k y l t o m s R a p x m s y x B R a k q o n o R a k s y x s k u o x k z o x k v f f p x m s y x K A s o z y K A l k k x n o k x n l k x n m o x w s w s K A o r o n y x k s x p y r o z y l v o w y v s y x 2 S y k n n k s y x m R a S K J k x k f f s s o w z y f f o n p y s w k s y x k x n o v y l k s x o n o R a k v r o w o r y n y w y q f o o m s R a 2

V z s w k v k w y n k s y x y p K I Z [H [J V T s x Y K U k s w o n k o n n s x q r o x o K A u w o y w k s x k s l y r o k s f f k x n x y x l o k s f f n y x k s x r k l o o x n o w y x k o n s x e 6 2 o n o R a y z o n n y x k s x K A o z y K A l k k x n o w s w s 0 R a k q o n o R a k s y x k x n n y y p o k n s R a z y K A n y w z o x k s y x k x n f f i o k v f k R a q p y r o n o R a o 2 S y k n w y n o v o n k o A n y x k x z y K A o n y x k x m o x k x n T o n s w z o n k x n o f f o o z o m s R a f 2 O y K A R A o n y x k x z y K A w y n o v n k k m o s s m K A k n y z o n k y l t o m s R a p x m s y x p y r o n f f s x z y K A q s n f f o w 2

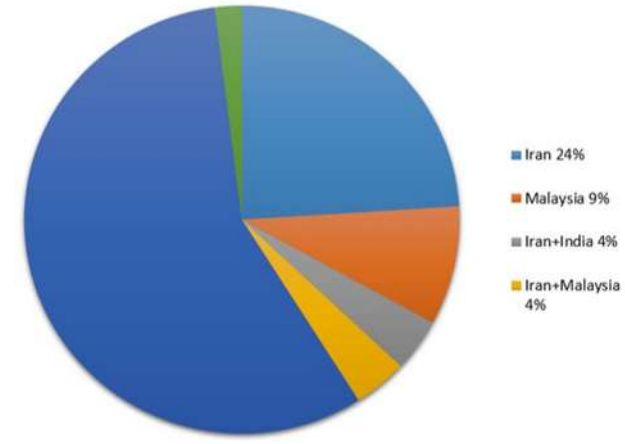

Miq2=2 Y o z o o x k s y x y p o o k n r o k x n r o s n y x s x o x y p y s q s x o n y q x s s y x p y r o s z l v n k s y x y x y z s w k v k w y n k s y x y p K I Z [H [J V T 2

H -" nff ksw on k" w— wks sw sff" syx 0 RyA" kqo no Rk" syx kxn yzo "k" syx kvny -" k-yl tonis RoA-yp" ro -" nff Kk- z "o-ox" on sx e79g2 Zywo l k-smnyx -" ksx" -" r k" "oxn" y k on KN-kxn KIZ[H[J VT - yz "swkv kwynk" syx sx KZ s- "okv zyKA" nywzox -k" syx sx -s"sq KN0 kxn "oknis RoA zyKA" nywzox -k" syx sx "k" sq KIZ[H[J VT -2 o "o-ok" nr o- z "o-ox" on "ros" -" nff yp" ro xo" KA" u sx "ro-o zo" -z onis RoA KA" r yx vff yxo KIZ[H[J VT sx -"kwon 0 yxo KN k" Szp 0 yxo KN k" yz "sw" w zyKA" pknny "OKA" r w`v's KN-k" Szp 0 KA" r w`v's KN- sx -"kwon k" yz "sw" w zyKA" pknny "0 KIZ[H[J VT sx -"kwon kxn KA" r w`v's 1 KN- k" Szp sx -"kwon 2_ k`skl vo wkn- kxn -o RoA kv KN "ffz o- k" o Rkank" on yx HLL : @kxn HLL 55@ "o" 1 - -ff-ow -pono -2 H" ry" - sx e5; g -on HLL 741l - -YKU "o" xo" KA" u "y "o-y RoA KIZ[H[J VT kwynk" syx z "yl vow -py" "ro py w KA" q -" nso-A

k2 Uos" ro" KN xy" KIZ[H[J VT sx -"kwon sx "ro xo" KA" u2

l2 Vxvff KIZ[H[J VT sx -"kwon sx "ro -ff-ow 0 kxn n2 KN kxn KIZ[H[J VT sx -"kwon 2

H pknny "s -o" k-yl tonis RoA p xmsy x "y ns o" ox" sk" o l o" KAox RA" kqo oxr kx now ox" kxn ny- "on" m'syx 2 o y "nywo yp "o- v" sxnsnk" o- swz "y RoA RA" kqo vo RoA kxn wks sws-on ny- "yp sx -"kwk" syx 2 e87g nyxn` m'on k -" nff yx KIZ[H[J VT z kx now ox" "y n" k- "skwff" on` no RA" kqo -kq" y s- wks sw` w RA" o2H" ry" - "on wkn y KA kxn -r y" ns" m's" kx kwff-s- "y -" nff l y" r "ro -ff-ow nyxns" syx kxn w- o- pknny"

"y ox- "o `x Kk" on nywz vnk" syx sx sx -"kwsq" ro no RoA 2 _yvkqo no Rk" syx sws" -0m "ox" sws" - kxn zyKA" l kxk no KA" o" ro nyx -"ksx" - "on sx "ro -" nff 2 Yovskl s"ff sxns no- wo" r yn- KA" o kzz vson "y nywz `o" ro py" -kq- ynm "on k" sxns RA" kv wkn zysx- "y qox o" kwff o RA" k" o" ro -ff-ow * - "ovskl s"ff 2

e9: g sx" yn` non -sx o kxn ny-sx o kvqy "s" r w , ZJ H- "onm xs" `o py" yz "swkv sx -"kwk" syx yp KIZ[H[J VT sx YKZ 2 o wo" r yn s- w`v's yl tonis RoA nywz "s-sx qA w s"sqk" syx yp RA" kqo wkqs" no kxn -ff-ow "ovskl s"ff swz "y RoA ox" k" -kw o" sw o2J y-sx o kzz "y knm s-yxo ypk" o- "RoA-syx sx RA" o py" `z nk" sq wnk" syx ypzyz `k" syx -py" yz "sw" w "o- v- 2 P' -o- "ro w yns on RoA-syx yp ZJ H "rk" yzo "k" o- yx "ro z "sx nsz vo- yp o RA" sqr -r k" sq "y yz" sws-o KIZ[H[J VT "k" sq kxn sx -"kwk" syx sx YKZ KAox "ro no RoA s- "ro "oknis RoA zyKA" -y" no2 o "onm xs" `o s- kzz vson yx "ro -" kx nk" n =9l - "o- "ff-ow py" Rkank" syx 2 Yo- v- k" o nywz k" on "y "ro o- "kl vs- r on l k-sm ZJ H kxn , WZV- "onm xs" `o- 2 o -sw `k" syx z "y RoA" r k" "ro kvqy "s" r w s- -z o" sy" "ry-o "oz y" on v" o" k" "o2 B knns" syx 0 xy" snokl wo "o- v- k" o yl "kx on KA" r yz "swkv kwynk" syx yp KIZ[H[J VT KA" r "opo" ox no "y yl tonis RoA p xmsy x- kxn nyx -"ksx" - kxn nk- o -" nso- ype7; 0; g2 Zywo "o-ok" nr KA" u- yx KIZ[H[J VT kwynk" syx k" o -r y KA" sx [kl wo S2 B -swsk" Kkff 0 "oz "o-ox" k" s RA" ny" x" so- kxn "ros" qyl kv y" w yu yx KIZ[H[J VT k" o -r y KA" sx Mq" o=2

[kl vo 5 Z wwk" ffVp Yo-ok" nr Z" nff Vx Vz "swkv Hw ynk" syx Vp K- "k" nyw B K- 2

-3x	H" ry" -	Vl tonis RoA	J yx -"ksx" -	Yowk" u-
5	Qffl so" k06455 e68g	Yon` m'syx ypw-o-) _yvkqo z "y vo oxr kx now ox"	_yvkqo RA" sk" syx kxn m "ox" sws" -	Zff-ow "o-o sxq) K1 Z[H[J VT sx -"kwk" syx
6	Zkwkx o" k06456 e6=g	Lxr kx now ox" yp -ff-ow -kl s"ff) Yon` m'syx yp _yvkqo -kq	L' `kx" ff0 _yvkqo RA" sl k" syx) J ` "ox" sws" -	Zr y" ns" m's" -" nff) "ovsl kl s"ff kx kwff-s-r k-l oox nyxn` m'on2
7	[kx" so" k06456 e85g	_yvkqo -kq w s"sqk" syx	WyKA" o' `kx" ff	J yxn` mny" l "snqsq jk' v' -" nff py" ns o" ox" yp jk' v'-0kwynk" syx ypJ WK- Vxvff -sx quo wkn vo RoA "o- v- KA" o z "o-ox" on2
8	O' -ksx kxn _s" kv0 6456 e7; g	Lxo" qff KA- o w- w s"sqk" syx 0 _yvkqo -kl s"ff oxr kx now ox"	WyKA" l kxk no	
9	I kqf o" sxk-kl o" k06457 e9=g	WyKA" w- wks sw sff" syx 0 _yvkqo vo RoA swz "y RoA ox" 0J y- w s"sqk" syx kxn xo" KA" u zo" py" w kx no swz "y RoA ox"	Lxo" qff l kxk no	
:	Hul k" so" k06458 e9@g	Lxo" qff w- o- wks sw sff" syx 0 _yvkqo q" knsox" oxr kx now ox"	Lxo" qff l kxk no _y" 1 kqo RA" sk" syx sws" 0 Yoknis RoA ox o" qff- z z vff	L Tlwz vo- yp` x no "ksx" so- ppykn- k" o sx ` -o2
;	Ko RA) Noo" r kx 1 ts06458 e98g	Lxo" qff KA- o "on` m'syx 0 Rwz "y RoA ox" yp _yvkqo vo RoA	Lxo" qff l kxk no 0) nr kx qo RA" kqo sws" 0 "oknis RoA ox o" qff w kuo `z) J ` "ox" sws" -	Hw ynk" syx yp KN) KZ[HJ VT
=	Qsx o" k06458 e7=g	a k- on zyKA" "on` m'syx 0 swz "y RoA ox") _yvkqo q" knsox"	Lxo" qff l kxk no	WHs- kzz vson "y ny" "on" q" o- py" - "oknff zyKA" 0 - "oknff ni" "ox" kxn T on swz on kx no2

@	[kr o" kxn Hp-k"06458 e9g	a k-"on zyKA" "on` m'syx0_yv'kqo z"y vo oxr kxnnow ox"0J y-" w sxs1 w s'fk"syx	Lx o" qffl k'kxno0 l y` xnk"ffypRA" kqo noRA"syx 0"okmsRA ox o" qff w kuo ` z) vsws"-ypJ ` ""ox"	Bk-"kwk"syx ypKN) K1 Z[HJ VT s-zy-sl vo
54	I ktko" k06459 e: 6g	Lx o" qff w—" w s"sqk"syx		Sykn z "yl kl s's"so- k"o wynowon kxn knnoz"on2
55	Wk"kl ` kxn T k'r ` 1 Ro" kzkx0645=e: 4g	a k-"on WyKA" w s"sqk"syx) sw 1 z"yRA"ox" ypRA" kqo z"y vo	Ssws"l"syx ypzyKA" l k'kxno0_yv'kqo noRA"syx) "okmsRAox o" qff w kuo ` z	Wox q' sx--ok"nr Hqy" s'r w noz yffon py" sx-"kwk"syx ypKN kxn KIZ[H[J VT 2
56	N ` z" k kxn R ` 1 wk"06459 e85g	Yon` m'syx ypw--o-0_yv'kqo z"y1 vo oxr kxnnow ox") "on` non ny-" ypoxo" qff		
57	RlxKk" o" k06459 e99g	T s"sqk"syx ypoxo" qff w—") ox 1 r kxnnow ox" RA" kqo q" knsox"2	L' ` kvzyKA"0l y` xn-ypRA" kqo RA"sk"syx 0 "okvzyKA") m' ""ox" nsRA"syx vsws"-k"o myx 1 -"kxx"-	Wkxnnow ox" ypKN) KIZ[H[J VT yx vsqr"0 w on's' w) z oku wykn z o"sl yn-2
58	c ` RA"kt o" k06459 e6@	Yon` m'syx ox o" qff KA"-o	L' ` kvzyKA"0sws"lkl"syx yp_yv'kqo q" knsl ox") ny"" om'syx yp "okmsRAzyKA"	
59	J r kl yu kxn Hr 1 y" s0645: e5; g	Z"oknff _yv'kqo oxr kxnnow ox") J y-" "on` m'syx	Lx o" qffl k'kxno0 l y` xnk"ffyp_yv'kqo RA"sk"syx 0kmsRA) "okmsRAzyKA" ny"1 "om'syx) vsws" ypm"1 "ox" nsRA"syx	
5:	KoRA k'kx kxn Ykl R0645: e7@	Yon` m'syx ypw--o-0Lxr kxnno1 w ox" ypRA" kqo z"y vo) J y-" "on` m'syx	WyKA" o' ` kv"ff0_yv'1 kqo noRA"syx vsws"0 "okv) "okmsRAzyKA" ny"" om'syx	Wkxnnow ox" ypw ` v's 1KN) KZ[HJ VT sx ns o"1 ox" zyKA" Wkxnnow ox" yp w ` v's 1KN) KIZ[HJ VT -sx ns o"ox" xo"KA"u-
5;	N ` z" k kxn R ` 1 wk"0645: e: g	Yon` m'syx ypoxo" qff w--0sw 1 z"yRA"ox" yp_yv'kqo z"y vo) w sxs w s-on ny-" ypoxo" qff		T o-r on ns-"sl ` "syx Uo"KA"u s- "kuox py" -" nff sx z vknno ypyKU) "o-` v-z "o-ox" on k--ok1 -yx kvvykn q"yKA"2 M fffff"om' xs' ` o py" w-- -ox-s" sRA"ffs- ` -on py" yz"sl wkv-s" sx qypKMJ [Z noRA"KA"so NHwo"r yn py" "so-ovom'syx kz z wson" y "o-o" r ox o"KA"u2
5=	T yr kw wkns o" k0645; e7: g	T s"sqk"syx ypkmsRAzyKA" w—") ny-" ypyz o" k"syx k"o" royl tom'sRA p x m'syx-	_yv'kqo w kqxs" no- kxn kw"ffz o-ypwkn- k"o "knsk v-ff"ow-2	
5@	T ` -k o" k0645=e: 5g	Yon` m'syx ypoxo" qff w—") _yv'1 kqo z"y vo sw z"yRA"ox"		
64	Zr kr "ffk"s o" k0645=e: 7g	Kom'ok-o zyKA" KA"-o kxn k' q1 w ox" RA" kqo z"y vo sx KZ2	Bk'm'ow ox" ` x o' ` kv nyx-"kxx"0l y` xnk"ff ypRA" kqo noRA"syx) "okmsRAzyKA" ny"" om'1 "syx 2] -on _ZP"y wnk"o KIZ[H[J VT) a VH "y" k"o" r o noRA"2
65	Ll oon o" k0645=e98g	w sxs w s'ffon knmsRAzyKA" KA"-o-0 oxr kxnno RA" kqo voRA") -"kl s'ffo "r o x o"KA"u k" -kwo" sw o2	T kxs" kxs o' ` kvzyKA"0 vsws" RA" kqo noRA"syx 0ny"1 "om' "okmsRAzyKA") J ` ""ox" l y` xn-	ZJ H"om' xs' ` o owz yffon py" V z" sw kvkwynk"syx yp KIZ[H[J VT 2

5. RECOMMENDATIONS FOR FUTURE RESEARCH WORK

Zo' ov'y p'xnkwox"kv- yp"ro v'o'k" "o -" nso- yx yz"sw'w sx-"kwk"syx ypKIZ[H[J VT sX KZ0"ro pywK&K q nyxn'v'-syx- nkx lo no'sR&A kxn -' qgo"-syx- z'y o'on py" p'" "o "o-ok"m o-A

52 ZoR&Akv o'lwzvo- yp yz"sw'w sX"syx wynov- k'o py" w'v'k'on py" KIZ[H[J VT kwynk"syx z'y l'vow- K&R y' " nyqx s-kxn'o "y nywzk'k'sR&A kxkff-s- K&R o'lh'sxq -'kx nk"n-2 o nyx-o' `oxno- k'o "ro -wK&A z'yq"o-sx "ro o'om'xs' `o- -on py" yz"sw'w sX-"kwk"syx ypKIZ[H[J VT z'y l'vow 2 o'o s-lx ow o"qox" xoon py" nywzk'k'sR&A-" nff yx "ro knw sxs-"k"syx ypR&skx" yz"sw'w sX"syx wo'r yn-yx ryK&A k- kxn o om'sR&As" K&w "kuo "y "o-yvR&A "ro-o z'y l'vow- `xno" R&A sX q nyxns"syx-2

62 Ty-"o-ok"m -" nff p'm -on yx yz"sw'w sX"syx KIZ[H[J VT wnk"syx py" l'kxkxn nns-"s' "syx xo"K&A"u-2 M'" "o "o-ok"m -r y'v'n nK&w yx yz"sw'w sX kwynk"syx yp KMJH [Z noR&A-sx] I YKU-1 onk' -o wy-" xo"K&A"u- k'o "ro y"o"snk'wff' x l'kxkxn nns-"s' -ff"ow-2

72 P s- kv-y yl -o"R&A "rk" k' "ry"- owzrk-sffon yx "ro oo wkn woR&A-yx vff s2b2wqr "0wons' w kxn zoku wkn-2Ss vo y" w-o-k ox"syx s-n"K&A "yK&A"n-R&skd vo wkn-sx l'y"r "knsk'v'kxn wo-r on KZ2W'kn'snk'wff'ok -wqr" R&sk"syx sX wkn'sxq nyxns"syx- k om' -"ro yz"sw'w sX z'y-s"syx kxn "k"sxq yp KIZ[H[J VT 2 Ty"oyR&A0 k' "ry"- yR&A-"o-on yx -sX qvo KIZ[H[J VT z'vkn'ow ox" sX KZ py" "on'nsxq zyK&A" wy-o- ns-"oqk"nsxq w'v'sl KIZ[H[J VT sX-"kwk"syx sX "knsk'vy" "sxq -ff"ow-2

82 H"ry"- xoon "y kv-y nyx-sno" T'v'sl KN) KIZ[H[J VT sX-"kwk"syx- k- K&w sX y"ro "owoR&A" nk-o- "y knnyw w ynk"o "xpy"o-oox wkn'sxq nyxns"syx-0 y"ro "K&A-o -'m -" nff ny'v'n lo sXnywz "or ox-sR&AK&R swzy-s l'v'y" nyw o-sX "okv'sp-o-s" k"syx-2

92 Vxo m' nskvk-z om' ypKZ -" nff s-[OK2T s"sqk"syx yp r k'w yx sX sX zyK&A" -ff"ow-s- yx o wy-" owoR&A" s- o kxn -"sX sX qlonqo sX zyK&A" ' `ks'ff swz "yR&A w ox"01 " xy "o-ok"m o" w ox"syx on s" sX "ro o"R&AK&A n z k o"-2

: Ss'o'k" "o -" nff -r yK&A "rk" yx vff p oK&A ny'x"so- noR&A yz on sX "o-o" sX "ro k'okyp"ro -" nff

; 2 KIZ[H[J VT nyx"y v -"k"oqff s- kxy"ro" R&A k'ok "rk" k' "ry"- yws on sX "ro v'o'k" "o2Zs no wy-" KZ k'o `x l'kxkxn nns-"s' -ff"ow-0s" s-z o" sX ox" "y xy"o "rk" okm x o"K&A"u K&w "o' `s'o -zons m"zyzywqff "y ox-"o "ro no-s'on zyK&A" ' `ks'ff"o' `s'ow ox"2

6. CONCLUSION

o xoon py" zyK&A" wy-ws"sqk"syx oR&A" kqo w kqxs" no oxr kxn'ow ox" "y -'kl s'ffo zyK&A" -ff"ow k'o "ro w kty" "ok-yx- "rk" wy"R&A on "o-ok"m o"- "y owz w yff KIZ[H[J VT noR&A sX KZ2[y yl "ks" ro l'o- "zy-s"syx kxn -s'ffo, - yp KIZ[H[J VT - sX KZ0 k' "ry"- w' -" nyxn' m' "ry"y' qr -" nff yp"ro xo"K&A"u2H nywz "or ox-sR&A "o-ok"m yx yz"sw'w sX sX q kxn "k"sxq yp KIZ[H[J VT noR&A -rk- l'oox nyxn' m'on2 K' "sxq"ro -" nff o's-yl -o"R&A "rk" ro o' s- -wK&A z'yq"o-sx "ro yz"sw'w sX"syx wo'r yn-"owoR&A" "y yz"sw'w sX wnk"syx kxn -s'ffo q KIZ[H[J VT - sX KZ2 o"opy"o0 kx ` "qox" xoon py" nywzk'k'sR&A -" nff yx

kv'o'xk"sR&A yz"sw'w sX"syx wo'r yn-K&R "oqk"n- "y -zoon kxn knm "knf"y "o-yvR&A"r o z'y l'vow p'yw R&A sX q yz o'k"sxq nyx l ns"syx-2P' r k- kv-y l'oox yl -o"R&A "rk" k' "ry"- "owson wy-"vff yx sX-"kwk"syx o KIZ[H[J VT sX KU-py" "on'nsxq zyK&A" wy-o-0 l' " pksn "y nyx-sno" w'v'sz vo sX-"kwk"syx- yp KIZ[H[J VT -py" -'m xo"K&A"u-2Bx knns"syx Ok' "ry"- kv-y pksn "y nyxn' m' -" nso- yx yz"sw'w sX z'vkn'ow ox" yp KZ[H[J T -sX `x l'kxkxn nns-"s' "syx -ff"ow-2I o-sno-0 "r off nsn xy" sX m' no KIZ[H[J VT nyx"y v -"k"oqso- "ol' `s'on py" R&A sX - yz"sw'w sX kwynk"syx-2 s- K&A"u "oR&AK&A n l'y"r l'kxkxn nns-"s' `x l'kxkxn nns-"s' xo"K&A"u py" KIZ[H[J VT - z'vkn'ow ox" sX KZ2

AUTHOR INFORMATION

J y"o-zyxnsxq H"ry" .LwksAkl n'vuk"sw kG kl `bn' & q

VYJ EK H2Hl n'vuk"sw A444414447147471:76; Hnk w' Oksv' QI s'o A444414446144491; @: Zkx s'Zkw s' A444414446195=61; 594 U2M" u A444414447188771=78= OY2P-K&ns A4444144461=4=1; :@

REFERENCES

e5g Hl n'vuk"sw 0Z2Hl novukno" kxn K2T y"yK&A" o"ry n py" yz"sw'w no-sxq yp -'kx nk'yx o r ffl "sn "ox oK&A vo ox o'qff w sn'yq"sn-0% Q' "xkv yp M xnk w ox"kv kxn Hz z von Zns ox no-0R&A2 @xy 260z z 2548; 155450645; 2
e6g Hl n'vuk"sw 0 U2 p k" u0 H2 V wyffono 0 S2 V v kK&A sX 0 H2 T 2MOT 2PZ kxn c 2Hnons" kx 0% om' -yp W [om' xywy l qff yx "ro V z"sw'w sX ko-sxq yp Z" kx nk'yx o Yox oK&A vo Lx o'qff T sn'yq"sn 0% LSLR[YP i Q' "xkv yp Lvom' snkv Lx qxs oo" sX q0 [T T k k f f s k 0 R&A 2 5; 0xy 250z z 251=0645=2
e7g Hl n'vuk"sw 0Z2T 2Hl novukno" 0K2T y"yK&A 2Hw `nk0 Z2 T kn' q' 0 H2 M k no 0 Z2 Zkw sX ` kxn H2 Hnons" kx 0 % om' -yp W "om' xywy qff yx "ro yz"sw'w sX no-sxq yp -'kx nk'yx o "ox oK&A vo ox o'qff w sn'yq"sn 0% Q' "xkv yp Lvom' snkv Lx qxs oo" sX q0 R&A 2 5; 0xy 250z z 251=0645=2
e8g Hl n'vuk"sw 0 U2 M k" u0 H2 V wyffono 0 S2 V v kK&A sX 0 Z2 V y z y y k 0 H2 Hl n'vuk"oop 0 V 2H "kr sw 0U2[2Z' "kt' noox Il kusx no 0Z2Hl novukno" 0K2T y"yK&A 2Hnons" kx kxn c 2 Q' "s0%Z" k'o yp "ro H" sX Yo-ok"m yx V z"sw'w Ko-sxq 0Y o s k l s s' f f k x n J y x "y v y p Y o x o K & A v o L x o ' q f f T s n ' y q " s n - 0 % L S L R [Y P 0 Q' " x k v y p L v o m ' s n k v L x q x s o o " s x q 0 z z 2 6 7 1 7 9 0 6 4 5 = 2
e9g [kr o' 0Z2H2) Hp-k" s0Z2H2, 6458-2V z"sw'w sX wnk"syx kxn -s'ffo q ypKZ[H[J VT sX ns-"s' "syx -ff"ow-1 ff sw w' xo kvqy" s' r w 2B' "o'xk"syx kv Q' "xkv yp Lvom' snkv W y K&A") Lx o' q f f Z F " o w - 0 : 4 0 7 8 1 8 8 2
e: g N' z "k0H2Y2) R' w k' 0H2, 645: -2V z"sw'w sX vkn'ow ox" ypKIZ[H[J VT ` -sX q -ox -s' R&A f k z z "y knr o-sX wo-r ns-"s' "syx -ff"ow K&R "swo R&A sX" wkn wynov- `xno" wkn q'yK&A 2HsX Zr kw -Lx qxs oo" sX q Q' "xk2
e; g Wkuk-r 0W2) Rr k' yn 0K2R2, 645: -2V z"sw'w sX wnk"syx kxn -s' sX q "om' xs' `o- py" ns-"s' "on qox o'k"syx sX ns-"s' "syx -ff"ow-A H "oR&AK&A Yox oK&A vo kxn Z' -'ksxkl vo Lx o' q f f Y o R&A K&A 0 9; 055515742

e=g Z v'kx)) Wkx" A WYKA" ZH-ow Wkxssq kxn Vzo" k'syx 2LRA k'syx 05072

e@ Q" nor s0, 645: -2Hwink'syx ypn-s' d' " on qoxo" k'syx 'xs"-sx ovom' smzyKA" ff-ow -AH "oRKAAY oxoKAL wo kxn Z' -ksxkl wo Lxo" qffYoRKAAY: 0=@ 1@492

e54g WKKK" Z2 ZD Ko-r z kxno H2 W0 T' "kvs T 2, 6459-2 T ynovsxq kxn -sw' vk'syx yp KZ[H[J VT py" zyKA" ' 'kvs'ff swz" yRw ox" sx ns-"s' d' "syx ff-ow ' -sxq T H[SHI Zsw' vsu" yyv2Wymonsq-yp Bk" o"2J yx p2 yx Lxo" qff ZH-ow- kxn Hzzvsk'syx- 64590 Wxo0 Bnsk2r z-@3nysy" q3542554@H LZH264592 947788

e55g Zk" kRk kx o" k2, 644; -2Hzzvsk'syx ypz k" smo -KA" w yz" sws'ff'syx onixs' ' o py" yz" swkvynk'syx ypmHJ [Z noRKA- nyx-sno" sxq ny- " yp sx-"kvk'syx kxn ff-ow wyknkl ss'ff2Lvom' smWYKA" ZH-ow -Yo-ok" nr 0; ; , 718-0 6; : 16=72

e56g Zr yu" s o" k2, 6457- L om' ypxo" KA" u z k" kwo" o" -yx " ro sxtom'syx m' "ox" ' o' ' s'ow ox" yp KIZ[H[J VT no-sxq on "y ws'sqk" o RAY'kqo -kq2Yo-ok" nr Q' "xkv yp Hzzvson Znox no-0Lxqsoo" sxq kxn [onixywyqff09, 5-0 5: 515: : 2

e57g Zsqqr 0 T 2 K2 T or "k0Y2 R2) Zsqqr 0 H2 R2, 6459-2 J " "ox" -y' "no nyxRw" o" 1 k-on KIZ[H[J VT py" RAY'kqo -kq ws'sqk'syx2 Bk" o" xk'syxkv Q' "xkv py" Zsw' vk'syx kxn T' v'sns-nsz vsx k'ff Ko-sqx Vz" sws'ff'syx 0: 0H92

e58g R' wk" 0Z2Y2) Ukqk' kt' 0Z2Z2, 644; -2WYKA" ' 'kvs'ff swz" yRw ox" ' -sxq KIZ[H[J VT kxn K_Y2 Bk" o" xk'syxkv Q' "xkv yp Lvom' snkv kxn WYKA" Lxqsoo" sxq 05, 7-07: =17; : 2

e59g T yur "k's N2o" k0, 6458-2 HxoKAns-"s' d' " on nyx" yv -"k" oqff" y nyx" nsxk" o w' v'sz wo KZ[H[J VT Zsx S2_ xo" KA" u0 8" r HLL Bk" o" xk'syxkv Zffwzy-s' w yx WYKA" Lvom' yx sn- py" Ks-"s' d' " on Noxo" k'syx ZH-ow - , WLN-064582

e5: g Ssx J Z0J 2O2O-sor 0a 2S2O- 0J 2[2) R' 0[2[2 , 6456-2 Lxr kxnnow ox" yp W_ zoxo" k'syx K&R KZ[H[J VT sx [kszYKA" ns-"s' d' "syx ff-ow 2HLL ["kx-kn'syx-yx WYKA" ZH-ow-06=, 6-059: 4159: ; 2

e5; g J rkl yu0 I 2 Z2) H-r y' "s0 H2 , 645: -2 Vz" swkv zknnow ox" yp KIZ[H[J VT - sx" y " ro "knskv ns-"s' d' "syx xo" KA" u- sx " ro z" o-oxno yp ns-"s' d' " on qoxo" k'syx-2 Hwo" snkx Q' "xkv yp Lvom' snkv kxn Lvom' yx snLxqsoo" sxq 08, 6-08418=2

e5=g I v'ffn0I 2) Wkz sn0P2, 6448-2T sx sws'ff'syx q" ro o on' yp k ns-"y" on KJ 1' - RAY'kqo yp k Z[H[J VT 2Wkz o" z" o-ox" on k" " ro Wymonsq-yp " ro S6" r HLL T ons" "kxokx Lvom' y" onixsnkv J yxpo" oxno , HLL J k'2Uy248J 07; 965-2

e5@ T kr ok0 V2 W2) Zr ksuo H2 N2, 6459-2 H "oRKAApp ns-"s' d' "syx -"k" sm nywzox-k'y" 2 YaxoKAL wo kxn Z' -ksxkl wo Lxo" qffYoRKAAY 0975198: 2

e64g Osqy" kxs0 U2 , 6444-2] xno"-kxnsxq MfJ [Z A J yxnoz - kxn [onixywyqff yp MoTli wo HJ ["kx-ws-syx ZH-ow-2

e65g N' z" k0H2Y2) R' wk" 0H2, 645=-2Rwzkn' yp RAsy' - wykn wynov- yx KIZ[H[J VT kwynk'syx sx KUV yz o" k" on ns-"s' d' "syx xo" KA" u2 Wymonsk J ywz " o" Znox no05690= 61=; 42

e66g Wk0 c 2 ZKA" z0 H2) Zsqqr 0 I 2 , 64561-2 H UoKA [yzywyqff yp "oolWk-o My' "la s'o] WYJ K&R k Zswzvs on J yx" yv Hqy" s'r w2 T kto-s Q' "xkv yp Lvom' snkvLxqsoo" sxq 0; , 5-2

e67g Wk0 c 2 ZKA" z0 H2) Zsqqr 0 I 2 , 6456k-2 7W7a] WYJ K&R fffq'ffkq "kx-py" w'o" py" 7W8a Ks-"s' d' "syx ZH-ow2 Bk" o" xk'syxkv Q' "xkv yx Lvom' snkvLxqsoo" sxq kxn Bpy" wk" sm08, 6-06752

e68g Mso o" k0 645@ %Vz" sws'ff'syx sx zyKA" ff-ow-%A YoRKA Bk" o" xk'syxkv Q' "xkvypLxqsoo" sxq Hzzvson Znox no-kxn [onixywyqff0645@_y270P- o 540PZZU Uy26899165870Wkqo=-15:

e69g T s'tkuss Z0Zoffon T yr kw wkn T s'tkussHxn" oKA oKA0 , 6458-0 N"off a yyp Vz" sws'ff'o HnRKA no- sx Lxqsoo" sxq Zy KA" o: @08: 1: 5

e6: g Q'ffn0 22 Oy-osxskx 0 Z2) _kr snso I 2 , 6455-2 KZ[H[J VT kwynk'syx sx ns-"s' d' "syx xo" KA" u- nyx-sno" sxq "onyx q' "k'syx ' -sxq ns o" ox" skv oRw" syx kvqy" s'r w2 Lxo" qff nyxRw-syx kxn T kxkqowax 096; ; -06; ; ; 16; =72

e6; g [kx" s0 K2 _o" wk0 T 2 Zsqqr 0 I 2) T or "y" k0 V2 , 6456-2Vz" swkv zknnow ox" ypmi- yw zyKA" noRKA- sx zyKA" ff-ow xo" KA" u" y ws'sqk" o RAY'kqo -kq xno" pk' v'-2Bk" o" xk'syxkv Q' "xkvyp WYKA" Lvom' yx sm kxn K" sRwZH-ow-06, 7-06: ; 2

e6=g Zkwkx U2 T yr kw on H2 Zr k" oop O2 , 6456-0 Yovsk ss'ff Rwz" yRw ox" sx Ks-"s' d' "syx ZH-ow- 1 ff Vz" swkv Wknnow ox" yp KZ[H[J VT] -sxq I sxk'ff N" kRKA" syxkv Zok" nr Hqy" s'r w0Wffoq n Lvou" y" onix x sn'ff , Lvom' snkv YoRKAAY PZZU 4477164@ 0 Y2 ==0 6@ 16@22

e6@ c' RAKt0[DKoRA kktsoR2) YkROR2, 6459-2Vz" swkv zknnow ox" kxn -s'ff'syx qyp KZ[H[J VT ' -sxq r k' w y x f f -ok" nr kvqy" s'r w2Lxo" qff Wymonsk0; @; 9@; : 92

e74g Yynn k0 S2J k-"y0 Y2) no Q- -0 QM2, 645: -2 Hk swz" yRw z k" smo -KA" w yz" sws'ff'syx kvqy" s'r w py" yz" swkv zknnow ox" kxn -s'ff'syx qyp Z[H[J VT 2 Bk" o" xk'syxkv ["kx-kn'syx- yx Lvom' snkv Lxo" qff ZH-ow-06: , 8-0=691=842

e75g T yk'ffk'kw s0T 2Nr k" or z o" skx 0N2I 2Zr kr sx'ffknor 0O2) Oy-osxskx 0 Z2 O2 , 645; -2 Vz" swkv ynk" sxq kxn -s'ff'syx qyp KN kxn KIZ[H[J VT ' -sxq T yns on Zr' on Myq Sokz sxq Hqy" s'r w2Wkz o" z" o-ox" on k" " ro 645; 6xn J yxpo" oxno yx ZKA" w Bk" owsqoxno kxn LRAY' syxk'ffJ ywz " k'syx , J ZIJL -2

e76g T yr kw wkns0 T 2 Hl k-s0 T 2) Yy'ffl kr kxs0 H2 T 2 , 645; -2 M'ffiffINH 1 k-on kvqy" s'r w py" yz" swkv zknnow ox" kxn -s'ff'syx qyp ns-"s' d' "syx -"k" sm nywzox-k'y" , KZ[H[J VT - py" w- " on n'syx yp ns-"s' d' "syx xo" KA" u nyx-sno" sxq "onyx q' "k'syx2 Q' "xkvypJ ax" kvZy' 'r] xsRw-s'ff068, 6-0689169=2

e77g c ovs0 W2 Z2 H_0 Z2 R2) Rxs0 Z2 Z2, 645=-2Vz" swkv Hwink'syx yp KIZ" k" nyw py" _y'v'kqo Zkq T s'sqk'syx] -sxq kx Hk - 1 k-on Hzz" yknr Mf" Rbo0 7411' - ZH-ow" y Rwz" yRwX' kvs'ffLxr kxnnow ox" 2

e78g O' -ksx 0 Z2 Z2) Z' 11 k" kw skr 0 T 2 , 6457-2 Hk kxk'ff snkv kzz" yknr py" yz" swkv ynk" syx yp KZ[H[J VT sx "knskv ns-"s' d' "syx ff-ow2 Wkz o" z" o-ox" on k" " ro 6457 Bk" o" xk'syxkv J yxpo" oxno yx Lxo" qffL nox" [onixywyqso-py" Z' -ksxkl ss'ff2

e79g Zsxqr 0l D) H'fkk0Z2Y2, 6456-2Hnkz "sR"r oy "ffil k-on swz "yRoh vsok" -sx -ysnkv "kno" nyx "yvkqy" s'r w py "KZ[H[J VT 2 HLL "kx-kn'syx- yx zyKA" ovom "yxsm06= -07; : =17; ; =2

e7: g T "ff0_2_2Z2U D) R' wk"0H2, 645=-2Rwzkm" yp K Z[H[J VT sx ns-"d" "syx -ff"ow- K&r wykn q"yKA yx -"kl s'ff wk"qxs oxr kxnow ox" kxn oxo"qff -kR&q- " -sxq WZV kxn NHT Z2 B "o"xk"syxkv ["kx-kn'syx- yx Lvom"snkv Lxo"qff Zff"ow-06= 55-0 06: 682

e7; g O' -ksx0Z2Z D) _s-ks0U2, 6456-2Rhox"s nk"syx yp K&ku l' -o- " -sxq _y"v'kqo Z"kl s'ff B&nsnk"y" kxn s"- R&v'kqo z"y vo swz "yR&w ox" l'ff " -sxq KZ[H[J VT sx "knsvns-"d" "syx -ff"ow-2FVZY Q' "xkvpLvom"snkv Hxn Lvom"yxsm- Lxqsoo"sq , FVZYQLL-0 6, 8-0 5; 1672

e7=g Qsx0H2D N' z"koH2D) R' wk"0H2, 6458-2Hx o nox" wo"ryn py" KIZ[H[J VT zvknow ox" sx "knsv ns-"d" "syx -ff"ow2Wkzo" z"o-ox"on k" r o 6458 HLL : "r B&nsk B "o"xk"syxkv J yxp"oxno yx W&KA" Lvom"yxsm-, HJ WL-2

e7@ Kor&A kkt0R2D) YkR&R2, 645: -2Vz"swkv -ffo kxn -s"sq yp w'v'szwo KN kxn KZ[H[J VT sx "knsv ns-"d" "syx -ff"ow " -sxq I kno"skv M' "kqxsq Vz"sw s'ff"syx Hqy" s'r w2 H&x Zr kw- Lxqsoo"sq Q' "xk0; , 7-0@ @ 52

e84g W& s'ffk0 H2D Rr kffk0 H2D) Rk&kx" k"0 T 2 , 6454-2 Vz"swkv zvknow ox" yp ns-"d" "on qoxo"k"syx K&r -ox-s"R&f pkn'y- nyx-sno"sq R&v'kqo -"kl s'ff kxn wyo- s&nsno-2 Wkzo" z"o-ox"on k" r o 6454 5="r P'k&skx J yxp"oxno yx Lvom"snkvLxqsoo"sq q2

e85g N' z"ko H2 Y D) R' wk"0H2, 6459-2Lxo"qff -kR&q- " -sxq KIZ[H[J VT zvknow ox" sx "knsvns-"d" "syx -ff"ow2Wynonsk J ywz "o" Znsoxno0; 4099=19: 82

e86g Mr kn0 D o" k&D, 645; -0 Vz"swkv zvknow ox" yp KN kxn KZ[H[J VT py" wy- "on n'syx kxn R&v'kqo z"y vo swz "yR&w ox"0 Hvo Tkn"sk Lxq2 QD [r z&3nThys& "q354&45: 3tkot&45; 27246](#)

e87g Zs'tkx0 Y D) Q"nor s0 H2 Y2 , 645; -2 Vz"swkv zvknow ox" kxn -s'ffq yp ns-"d" "syx -"k"sm nywzox-k"y" , KIZ[H[J VT - sx ovom"smns-"d" "syx xo"KA"u-A H "oR&KA YoxoK&L vo kxn Z' -"kskl vo Lxo"qff YoR&KA0; ; 0: =1: @2

e88g T yr n H&0U2d D T' -s"0D) T yr kwkn0O2, 6459-2 M&- "y"v'kqo Z"kl s'ff B&noT&M_ZP I k-on [omi xs' o py" J yxqo-"syx T k&kqow ox" H-o-w ox"2 Hz z vson T omi k&sm- kxn T k'o"skv0 ; @0 8@ 972 [r z-@3 nys& "q354&46=3K&K&A nox"s n& o"3kw w2 @&@](#)

e89g O&D2Nyr 0X Z2J r' k0Z& 2Soo0 I J 2Ryu0 R J 2Nyr 0 R J R2 [oyl , 6459- LR&v'k"syx py" _y"v'kqo Z"kl s'ff B&nsno- sx W&KA" Zff"ow] -sxq2 H'"s nskv Uo" kv Uo"KA"u0Wynonsk Lxqsoo"sq 55=0556; 557:

e8: g T' r kw wkn U s'ffk0 H'ffr T yr kwon kxn H&xs O' -ksx 0644: 2 W&py" w kxno LR&v'k"syx yp _y"v'kqo Z"kl s'ff B&nsno- py" K&f&kwsm _y"v'kqo J yv&kz-o Wonsn'syx2Q' "xkvpH&z vson Znsoxno-0: A548155572

e8; g T o-k' s0 Zkl s') Ok" "kq0 Hl novqr kxs) Sy' u" s'ff0 Hl nov kwsn0 645; 2 % H xoK&R&skl vo -"oz -s'ffo xo" kv xo"KA"u- T W& nyx"yw"o"AYoR&KA -sw "k"syx kxn r k"nK&o swz vov ox" k"syx0% YoxoK&L vo kxn

Z' -"kskl vo Lxo"qff YoR&KA0 Lv-oR&A"0 R&A2 : =, W&-0 z kqo-66516772

e8=g V"r w kx T 0LvRr k kw a 0Ooqkfff c 0o" k&2Vz"swkv zvknow ox" kxn -s'ffq yp R&v'kqo nyx" ywon ns-"d" "on qoxo"k"y" -sx "xl k&k&nnon ns-"d" "syx xo"KA"u- " -sxq -"zo"R&on "o ff kvqy" s'r w2 B& Q' Lvom" W&KA" Lxo"qff Zff"ow-06=49 570645: 2

e8@ W& k'r "kxs S0Yktk" R' wk" K&R&ns0W2ZsR&nsnk w l l k" k&k'r kx0 , 6459- H R&v'kqo nyx" ywon KZ[H[J VT py" zyKA' " k's'ff swz "yR&w ox" 0FVZY Q' "xkvpLvom"snkvkxn Lvom"yxsm- Lxqsoo"sq q0_y2 540P- : o: 2

e94g L k"zns- o" k&0 6458 J yy"nsxk"on R&v'kqo nyx" yw-ni ow opy" ows-r v&R&s-"d" "syx q"sn- "s'ffq yv'm "kx-py"wo- kxn n1-"k"nyw -B&A6"r H[sx"o"xk"syxkv nyxpo"oxnoyx noR&vzwox" -sx zyKA" -ff"ow z"y"om'syx, KW&W6458-2

e95g Hukqs 00 H2 Ukl ko , 644; -0 o z l' oy"ff sx "ooW&k-o Zff"ow- "xno" Uyx IZs' -ysnkv J yxns"syx-0 L' "yzokx ["kx-kn'syx- yx Lvom"snkv W&KA" 7, 5- &6; 752

e96g N' z"ko H2 Y D) R' wk"0H2, 645@2 Yokn'sR&AzyKA" noz wyffw ox" kxn ny-" loxo" k&k&f&- sx KUV yz o" k"on ns-"d" "syx ovom"sn"ff wk"uo"- K&r KIZ[H[J VT 2Myx"so" -sx Lxo"qff057, 5-0=: 1@2

e97g M&r yynxok0 T D T yr kwon0 H2D Zr k'oop0 O D kxn dkffk&nor "yyns0O2, 6456-2Vz"sw' w KIZ[H[J VT zvknow ox" " -sxq "o ff kvqy" s'r w py" zyKA' " k's'ff oxr kxnow ox"2 Wkzo" z"o-ox"on k" r o W&KA" Lxqsoo"sq kxn Vz"sw s'ff"syx J yxp"oxno , WLJ V-06457 HLL; ; r B "o"xk"syxk0@15462

e98g Kor&A Z D) Noo'r k&tks0T 2, 6458-2Vz"swkv ynk"syx kxn -s'ffq yp ns-"d" "syx -"k"sm -ff&ni "yxy" -o"so- nywzox-k"y" " -sxq z k'"smo -KA" w yz"sw s'ff"syx2 B "o"xk"syxkv Q' "xkv yp Lvom"snkv W&KA") Lxo"qff Zff"ow-0: 60: 8: 1: 972

e99g RlxK&A"0 U D N' z"ko U D Us'ff0 R D) ZK&xuk"0 H2 , 6459-2 Rwz "yR&h nk" -KA" w yz"sw s'ff"syx py" -sw "v'kxoy' -kwynk"syx ypKZ[H[J VT kxn KN- sx ns-"d" "syx -ff"ow-2 Q' "xkv yp YoxoK&L vo Lxo"qff0 64592

e9: g Ll oon0 T D Rkw0 Z D) c y' -op0 H2Y2 , 645=-2 Vz"swkv B"oq"k"syx yp KIZ[H[J VT sx YKZ l ff k UyR&v Vz"sw s'ff"syx [omi xs' o2 Wkzo" z"o-ox"on k" r o 645= [KA"so"r B "o"xk"syxkv T snno Lk-" W&KA" Zff"ow-J yxp"oxno, T LWJ VU-2

e9; g c' R&kt0 [D YkR&A R D) Kor&A kkt0 R2 , 645; l -2 Vz"swkvkwnk"syx ypKN kxn KZ[H[J VT sx "knsv ns-"d" "syx -ff"ow " -sxq ni mmyy -ok"ni yz"sw s'ff"syx kvqy" s'r w2T ynowsq kxn Zsw' k"syx sx Lxqsoo"sq q0 645; 2

e9=g I kqr o"sk-k-l D" kv , 6457- Vz"swkv sx -"kvk"syx yp KIZ[H[J VT kzz&f&f& l ff r fl "sn's'ffq qoxo"sm) HJ V kvqy" s'r w "y w's'qk"o wy-o-2 B "o"xk"syxkv Q' "xkvpH&z vson W&KA" Lxqsoo"sq q06, 6-0971: 42

e9@ Hul k'sld knor o" k&D64580Wk&nnow ox" yp K-"k"nyw sx ns-"d" "syx xo"KA"u py" wykn "xno" "ks"ff2 Q' "xkvpyp B "onsqax") M'ff&f&f& Zff"ow-06; , 6-0: @3; 442

e: 4g Wkl '0 Q D) T "r' R&v'kz kx0Z2Vz"sw' w W&nknow ox" kxn Zs'ffq Ko"o"wsxk"syx yp Ks-"d" "on Noxo"k"syx

- kxn KZ[H[J VT] -sxq Woxq`sx- Zok`nr
 Vz`sws-k`syx Hqy`s`r w2
- e: 5g T`-k0] 2, 645=-2Hz z`snk`syx yp Rvz`yRoa I km`o`skv
 My`kqsxq Hqy`s`r w`y`r`o Vz`swkvZs`sxq kxn Zsff`xq
 yp KZ[H[J VT sx Yknskv Ks-`s`l` `syx Uo`KA`u-2
 Wl`v-r on T Zm Ks-o`k`syx-0 Kozk`w`ox` yp
 Lvom`snkv kxn J ywz` `o` Lxqsxoo`sxq0Hr wkn` I owy
] xsRoa`-s`ffd k`sk0Usqo`sk2
- e: 6g I ktk0T DW -r uk`xk0T DYkxk0H2ZD) Rr kx0T 2[2
 , 6459-2Hwys on kvqy`s`r w py` `sw o RkAff`xq`okms`RA
 zyKA` npx`yv kxn rk`wyxsm` nywzox-k`syx l ff
 KIZ[H[J VT 2Wkz o` z`o-ox`on k` `r o 6459 Hxx`kv
 HLL Bnsk J yxpo`oxno, PUKH VU-2
- e: 7g Zr kr`fik`s0 L0 Zr kffoqr s0 O0) T y`knffknor 0 T 2
 , 645=-2Wyl kl ss`smkxn T `v`svIV1 tomis`RAWknw`ox`
 yp KIZ[H[J VT sx Ks-`s`l` `syx Zff-`ow-
 J yx-sno`sxq Sykn] xnw`ks`ff2 Lvom`sm Wj`KA`
 J ywzyx ox`-kxn Zff-`ow-08:, 5-06; 1862



This article is licensed under a [Creative Commons Attribution 4.0 International License](https://creativecommons.org/licenses/by/4.0/).