

Failure Analysis of High-Pressure Turbine Blades in Steam Power Plants



J' uuvfJ xZfTh~ -lafI' oTh~ IJ v~ or UotTttwX offlfw' /

Ms° oTh s' fi-t Wsqvo' wqoz N uwss' tku1Oqfzfi -t N uwss' tku1c' vts' tffoffWflvo~ ~ or wov] voflZsyo' po'fhl] vofl 7A7B91
S r-' sffio

J Kab LbC vff° o'sThsffq' pssff fivs tovfTh~ -t vvvv2' tffiffThffis o~ fl' p' hws p' zors sff Ml' tku fivs as' tku1ff S ff sqfw' 1 v' tt off r vff-fs' t' r fiv ofi fivs ' w' fiv 2ffous vvvv2' tffiffThffl' p' zors vor tovsr3 s' qoffffsff -t p' zors tovfTh o' h's s~o- wsr f' v' f' f' loz w' ff sqfw' o' r r s' f' f' h' q' f' f' s' f' f' w' u3 s' tovfTh~ -sqvo' vff~ -t fivs p' zors sff tt off r s' f' s' Th wsr p' q-' r fl' q' f' u ~ sqvo' wqoz° H' s' Thsff f' s' f' f' w' u1 ~ sfozz-u' t' v' v' q' w' ff sqfw' 1 o' r s' s' Th ff sqf' h' o' oz f' f' s' s ~ sqvo' wqoz° H' s' Thsff -t fivs z' s' o' t' o' r' Th- fi p' zors ff sqw' s' f' f' t' s' t' h' t' v' w' f' f' v' s' Th us -t p' zors f' f' s' s' z' t- Th' f' s' o~ fl' p' h' w' s' f' f' o' q' -t' h' v' u fi- fivs L' v' w' s' f' s' X' o' f' w' o' z' a' f' i' v' o' r' Th- P K4b A@72 7559. 1 p' f' i' f' i' f' i' v' s' q' v' s~ w' q' o' z' q~ ~ -f' f' w' v' t' t' o' f' f' -f' i' w' s' f' i' q' o' z' v' v' v' q' -f' f' w' v' s' f' i' t' t' v' v' f' i' v' s' Th- fi p' zors t' t' h' q' f' f' Th' o' s' Th t' v' s' Th f' i' v' s' v' o' t' h' s' f' f' f' o' z' l' s' z~ sr t' Th- f' i' v' s' f' i' f' i' t' h' l' z' f' f' v' f' f' i' v' s' z- t' s' f' f' i' o' f' i' v' s' Th- fi p' zors z- q' o' f' w' 1 t' t' v' v' q' v' f' f' i' v' s' ° t' h' o' Th q' o' f' f' s' -t' f' f' l' Th ° H' o' u' o' f' w' 3

Us tt- t' h' f' f' C' o' v' f' l' Th' o' oz f' f' i' f' f' l' p' h' w' s' p' zors l' t' o' f' w' u' l' s' l' t' h' q' f' i- u' t' h' v' 1~ sqvo' wqoz° H' s' Thsff

1. INTRODUCTION

S o° -tts' Th' o' q' u' v' i' l' f' f' s' o~ fl' p' h' w' s' p' zors s' f' f' i' t' h' ff- Th fivs z' v' s' o' Th -f' w' -t v' v' v' 2' f' s~ ° s' t' h' f' i' l' Th v' v' v' 2' t' h' f' f' l' Th f' f' s' o~ w' f' f' i' v' s' H' f' o' Th~ -f' w' -t f' i' v' s' fl' p' h' w' s' f' f' v' o' i617k3t fivs p' zors s' f' -t fivs fl' p' h' w' s' tovfTh fivs ° -tts' Th' o' q' u' v' i' t' t' v' z° s' t' h' v' 3 v' f' v' o' f' f' f' i' v' s' ° -f' i' s' f' i' v' o' z' f' i' q' o' f' f' s' q' -' ~ v' q' z- f' f' f' f' w' f' i' v' s' r' v' f' f' f' f' i' v' z' o' f' f' f' i' t- Th o' s' z' s' r' s' r' ° s' t' h' r' -t f' i' v' s' 3b- w° H' f' s' f' i' v' s' t' h' o' p' v' i' t' -t f' i' v' s' fl' p' h' w' s' f' f' f' i' s' ~ 1 v' v' v' f' s' q' s' f' f' i' t' h' fi- o' oz f' f' i' v' s' tovfTh -t f' i' v' s' fl' p' h' w' s' p' zors s' f' f' z' h' t' v' f' l' f' f' t' h' s' o' t' h' v' v' o' f' f' r' s~ -' f' f' i' f' i' s' r' f' i' v' o' f' i' q' t' s' ° r' o~ ous1 t' o' f' w' u' l' s' l' q- t' h' f' i' v' 1 s' t' h' f' i' v' 1 o' r' s' f' i' v' h' ~ s' f' o' z' o' q' y' -s' w' o' f' w' 1 v' s' o' f' i' q- t' h' f' i' v' 1 s' t' h' f' i' v' 1 o' r' t- t' h' u' ~ o' s' Th r' o~ ous. o' h' f' i' v' s' ~ -f' i' o' t' h' z' o' s' f' i' t' o' v' l' Th ~ sqvo' vff- ff t- Th fl' p' h' w' s' p' zors s' f' i' 8k3J q' q- t' h' v' u fi- L' o' v' o' r' w' t' W3 fivs ~ -f' i' q~ ~ -' q' o' f' f' f' f' -t w' x' l' Th fi- f' f' i' s' o~ fl' p' h' w' s' p' zors s' f' o' h' f' f' i' s' f' f' q- t' h' f' i' v' 1 r' s~ -f' i' o' f' f' t' t' o' f' s' Th' H' f' i' v' 1 o' r' t' o' f' w' u' l' s' i9k3e v' v' s' U' f' l' p' w' o' y' a' l' B' s' f' i' o' z' 3' -f' i' s' r' f' i' v' o' f' i' f' l' p' h' w' s' p' zors Th- fi tovfTh fi ° w' o' z' z- q' q' l' Th w' v' v' v' 2' f' i' s' f' f' f' q- ' q' s' f' i' t' h' w' -' s' f' f' o' f' o' t' h' f' i' z' i' -t' f' f' i' f' l' h' q' f' f' l' t' h' -Th~ o' f' s' t' h' z' us ~ s' f' i' q' r' v' f' q- f' i' v' f' l' v' o' f' i' : k' l' f' i' v' v' f' v' f' -f' i' l' v' s' t' h' o' z' f' i' v' s' q' o' f' f' 3

v' f' s' z' q' f' i' l' q' f' f' s' o~ ° -tts' Th' o' q' u' v' i' t' t' v' v' o' q' o' q' u' v' i' -t 7 ≤ 68: We v' o' f' f' p' s' s' -° s' t' h' w' o' z' f' i' v' q' s' 756: 3 O' h' -f' i' v' s' f' f' o' Th- t' -° s' t' h' w' -t f' i' v' s' s' z' q' f' i' l' q' f' f' s' o~ ° -tts' Th' z' o' f' i' f' i' v' 75761 f' f' f' s' t' h' z' ~ o' w' f' i' s' o' q' s' o' q' f' i' v' o' f' f' v' o' f' s' p' s' s' ° s' Th' H' s' r' l' w' q' z' l' w' u' as' t' h' f' l' f' f' S' f' f' sqfw' -a S ~ o' w' f' i' s' o' q' s' 3 M' l' t' k' u' f' i' v' s' c' v' a' 6 as' t' h' f' l' f' f' S' f' f' sqfw' 1 v' v' t' t' o' f' f' r' v' f' f' -f' i' s' t' h' r' f' i' v' o' f' i' f' i' v' s' ' w' f' i' v' 2' f' f' o' u' s' v' v' v' 2' t' h' f' f' l' Th' f' l' p' h' w' s' p' zors vor tovsr 3

d' w' f' l' o' z' w' f' f' sqfw' o' r' -' r' s' f' f' i' h' q' f' i' s' f' f' i' v' u' o' Th ° s' Th' H' s' r' t- Th' v' v' f' ° H' s' q' f' b- r' s' f' s' Th' w' s' f' i' v' s' tovfTh ~ sqvo' vff- -t f' i' v' s' p' zors s' f' l' ~ sqvo' wqoz ° H' s' Thsff

~ sfozz-u' t' v' v' q' s~o- w' o' f' w' 1 ~ w' Th' v' o' Th' s' f' f' i' q' o' ' w' u' l' o' r' s' s' Th ff sqf' h' - f' i' f' i' v' u' t' t' s' t' h' o' z' f' ° s' Th' H' s' r' -' t' h' q' f' f' f' f' b

2. EXPERIMENTAL WORK

S f' i' v' v' f' ° s' Th' f' i' v' s' r' o~ ousr B' i' v' f' f' o' u' s' fl' p' h' w' s' p' zors -P K4b A@7. t' Th' o' 68: We u' o' f' f' fl' p' h' w' s' t' l' q' f' w' w' u' o' f' i' : 8: L' v' f' w' f' s' f' f' w' o' f' s' r' 3 O' u' f' l' Th' 6 r' s° w' f' f' o' r' o~ ousr fl' p' h' w' s' p' zors o' r' o' oz f' f' i' f' f' o~ z' v' u' 3 K' s' u' w' w' u' t' t' v' v' f' o~ z' s' f' w' o' q' q' s' f' o' p' z' q- ' r' v' v' w' -f' f' o~ z' s' f' f' 6 o' r' 7. 1 r' o~ ousr fl' p' h' w' s' p' zors f' f' o~ z' s' f' f' -f' f' o~ z' s' f' f' 8 fi- 6; . o' h' f' i' v' s' q- z' s' q' f' s' r' 3 b' o' p' z' 6 ° H' f' i' v' s' f' f' i' v' s' q' v' s~ w' q' o' z' q~ ~ -f' f' w' v' -t f' i' v' s' f' l' f' s' r' ~ o' f' s' t' h' z' o' r' f' i' v' s' f' f' o' r' o' Th ~ o' f' s' t' h' z' 3 s' w' f' i' v' 2' f' f' o' u' s' fl' p' h' w' s' p' zors t' t' o' f' f' l' i' v' w' s' r' fi- w' f' s' f' f' w' o' f' s' o' r' s' f' o' z' l' o' f' s' f' i' v' s' f' f' sqf' h' -t q' v' s~ w' q' o' z' q~ ~ -f' f' w' v' 1 ~ sfozz-u' t' v' v' q' o' oz f' f' i' l' ~ w' Th' v' o' Th' s' f' f' i' s' f' f' i' l' o' r' ~ w' Th' f' f' i' q' -° v' q' o' oz f' f' i' l' -t tovfTh c' f' f' i' v' u' o' -° f' i' q' o' z' ~ w' Th' f' f' i' q' -° s' -Y z ~ f' l' f' 2' P' f' : 61 ' t' o' . 1 ~ sfozz' q' f' f' i' h' q' f' f' l' t' h' f' f' o' r' w' q' z' l' f' i' v' f' f' t' s' Th- p' f' s' Th' r' 3 s ~ w' Th' v' o' Th' s' f' f' i' -t f' i' v' s' f' f' o~ z' s' t' t' o' f' f' ~ s' o' f' f' l' Th' f' i' f' i' v' u' o' ~ w' Th' v' o' Th' s' f' f' i' w' f' f' i' h' -s' f' i' q' o' z' p' t' h' s' r' fi- f' i' v' s' J' a' b' W' N8A926 f' f' i' v' o' r' o' Th' 3S f' i' v' s' ~ s' o' f' i' v' s' l' o' a' q' o' ' w' u' N' s' q' f' i' h' W' w' Th' f' f' i' q' -° s' N' s' Th' M' v' f' s' Th' f' i' s' f' 2] o' a' s' q' f' i' h' f' i' q' -° -a' N' W' 2' N' M' a' 1' R' v' o' q' v' w' O' s' s' a' N' W' 6551' t' o' . o' r' z- q' o' z' q' v' s~ w' q' o' z' o' z' f' f' i' l' -t f' i' v' s' fl' p' h' w' s' ~ o' f' s' t' h' z' t' s' t' h' f' l' f' s' r' fi- w' f' s' f' f' w' o' f' s' r' o~ ousr fi- fl' p' h' w' s' p' zors t' h' q' f' f' f' f' b

Received : Wo 6917578
Revised : Thz 6717578
Accepted : Thz 6917578

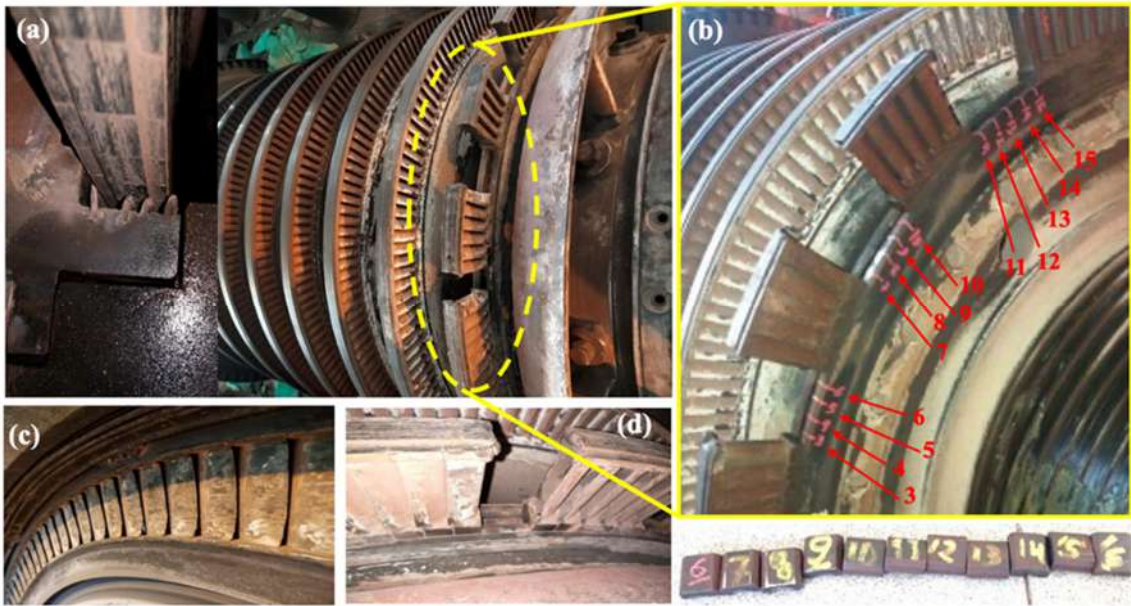

Ona363 s us' s' t'z f'wtt -t r o~ ous w f'v s uoff fl' t'w s p'z o r s f'f-o. r o~ ous f'f- f'v s ' w' f'v f'f'ous fl' t'w s p'z o r s -p. f'f o~ z'v u° -f'f'w' t' t' h~ f'v s t' h~ f'f- t' f'v s uoff fl' t'w s p'z o r s -q. r s t- t' h o f'w' -t v w u 2' t' f'f' f'f' h'f'f' s o~ 2' f'f' t'w s r w° v' t' u~ -r. f'f o~ z'v u° -f'f'w' f'f o' r 7- w u~ r q- ' r w'w' . 3

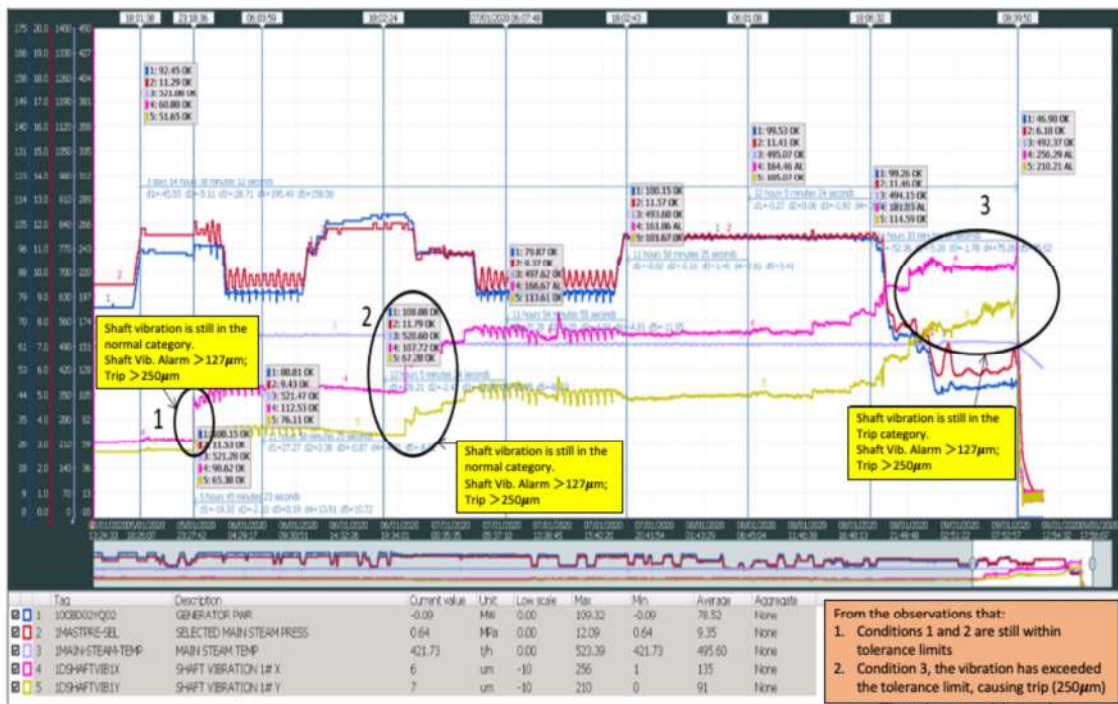

Fig. 2. Trending operations of turbine parameters.

3. RESULTS AND ANALYSIS

Y° s' t'w' Mofa

Oh~ f'v s f'f' h~ r -t f'f' t'w s -° s' t'w' u° o' t' h~ s' f'f' h~ r o' f' o' l w' q' z' r' w' u' f'v s q- t' h o f'w' -t° -t' t' s' t' h° t' f'f' f'f' t' h~ -t t~ o' w' f'f' s o~ l o' r f'f' u' t' w' r' f' f' t' h' u' f'v s ~-' f'v ° t' h' s' r' w' u' f'v s r' w' q- f'f' s' t' h~ t' f'f' t'w s p'z o r s t' o' v' e' l' t' h' r' f' f' t' h' u' %° s' t'w' o' z' v- f'f' t' h' s' f'f' u' t' w' w' f'v s' -t' h' o' z' t' h' u' s' l' t' t' w' o' f' o' z' f'f' s -t' B A 3 7 ~ l p' o' f' f' r -' f'v s t' f'f' f'f' f' -t -p' f'f' t' h' o f'w' f'f -t f'v s f'f' r' s' q -t f'v s f'f' t'w s -° s' t'w' u° o' t' h~ s' f'f' h~ -O n a 3 7 . 3 S

o r r w'w' 1-' s r o o s' t' h' s' f'f' i' f' l- p' s' t' h' f'v s f'f' w' v' q' f'f' h~ r w' q' t' h' o f' f' r f'f- 6 5 @ @ ~ 3 J f'f' v s f'v w' h' s' f'f' s' f'f- o s' t' h~ f'f' t' h' o f' f' l f'v s f'f' u' p' t' w' w' z' f'f' s' z' s' q' s' r' s' r' f'v s o' z' t' h' f'v t' h' f'f' v -x -t 6 A 6 3 8 ~ r o' f'f' v o f'f' u' p' t' w' w' t' t' o' f'f' w' f'v s b' t' h' q' o' f' s' u- t' h' s' f'f' v o f'f' u' p' t' w' w' o' z' t' h' z' w' v' i' t- t' h' a' f'f' s o~ Z- t' t' s' t' h' z' w' f'f' w' f'f' 6 7 @ ° s' t' h' S a Y 6 5 A 6 ; 2 7 - W s' q' v o' v' q' o' z' f'f' u' p' t' w' w' . t- t' h' f'f' s o~ f'f' l' t'w s' f'f' o' r u' s' s' t' h~ f'f' t' t' v' v' s' f'v s f'f' h' h' z' w' v' i' w' f'f' 7 : 5 ~ 3 S o r r w'w' 1 o L a S 7 ; 5 5 f'f' u' p' t' w' w' o' z' s' t' h' t' o' f' f' f' f' r' f'f- ~ s' o' f'f' l' t' h' f'f' u' p' t' w' w' f'f' o' r r' s' f'f' s' t' h' w' s' f'v s r ~- w' o' f'f' f' s' q' f'f' h~ 3



Ova393WocHffq-° vq o°° s o'lh qs -t fivs r o- ousr pzor sfb



Ova3: 3WocHffq-° vq o°° s o'lh qs -t fivs pzor s ffr-tt w u° w w u q-Tlhfiv' 3

b opzs 63Lvs~ vqozq~° -ffiv' -ttf) . 3

	L	aw	W'	Z	a	LTh	W-	Lfl	Xw	d	e	Qs
a° sqw s'	5395	5389	5397	5386	537:	663;5	5387	53: 7	536@	5385	2	Koz3
P K4b A@7Z5S9i @	5375 53:	535	535 635	5385	537:	663 673	5385 63:	53:	535 635	5375 5385	5385 63:	Koz3

Lvs~ vqozq~° -ffiv'



s qvs~ vqoz q~° -ffiv' -t fivs pzor sff vif o' oz sr flffvu -° fivqoz s~ vffiv' ff sqfHffq-° -Y Na. 3 Lvs~ vqoz o' oz fiff flffs off fiv ofivis pzor s ~ ofis 'koz vif ffs o~ fl' hws pzor s ffs sz b opzs 6 flf~ ~ o' lff ff fivs Rho' fivofifs qvs~ vqoz q~° -ffiv' -t fivs ff sqw s' ff 'krofifs fi- fivs ffo' r o'lh Lvwsff ffs o~ fl' hws pzor s ~ ofis 'koz -P K4b A@7Z5S9. 3 Koffr -' b opzs 6 ffr ofo l vif s fws' fi fiv ofivis qvs~ vqoz q~° 2 ° -ffiv' -t fivs ff sqw s' ff o' r fivs ~ ofis 'koz q~° -ffiv' -t fivs Lvwsff ffo' r o'lh ffs o~ fl' hws pzor s ffr ws Th

WvqHfflthqffl'kz s ffozlofiv'

s r ofo t'lh~ ~ vqHfflthqffl'kz-pffs 'thofiv' ff o'lh foplfzofsr fi-toqvwofis ws' fivqofiv' o' r toqvwofis r ofo q-zs qfiv' 3Wflzfvz

ffo~° zs flffo~° zvu° -wffil o' r z-qofiv' ff tts'kz-pffs 'lhr t~Th fivs vth ~ vqHfflthqffl'kz J qq-'thvu fi- fivs ~ vqHffq-° vq -pffs 'thofiv' ff 'kffs' fsr w b opzs 71 fivs ~ vqHfflthqffl'kz vif fs~° s'kz ~ o'lh' fivs w ttvqv° s'kz wofiv' voff psufl' fi-r sfsz~° 3 s ~ vqHfflthqffl'kz-t ~ o'lh' fivq ffov z s fff ffs sz vif ~ o'lh' fivs fivofivoffps' Rhs' qvsr o' r fs~° s'kz r fl'khu fivs pzor s ° 'Hr flqfiv' ° 'Hqsfff iAk3e vws fivs ff vs 'hw qo' ps oqqs z'kfs r p -° s'kz fiv ofivv vws ~° s'kz fl'kffl off r s° vqfvr w Ouf'kz 7 -t b opzs 71 fivs ~ vqHfflthqffl'kz xopsz 6J 3 voff o qo'pws rws' fiv' fiv ofi vif -' ofis 'kz l ff-ozs 'lhfiv' fivs ~ vqHfflthqffl'kz-t fivs ffo~° z s pzor s 16: 3

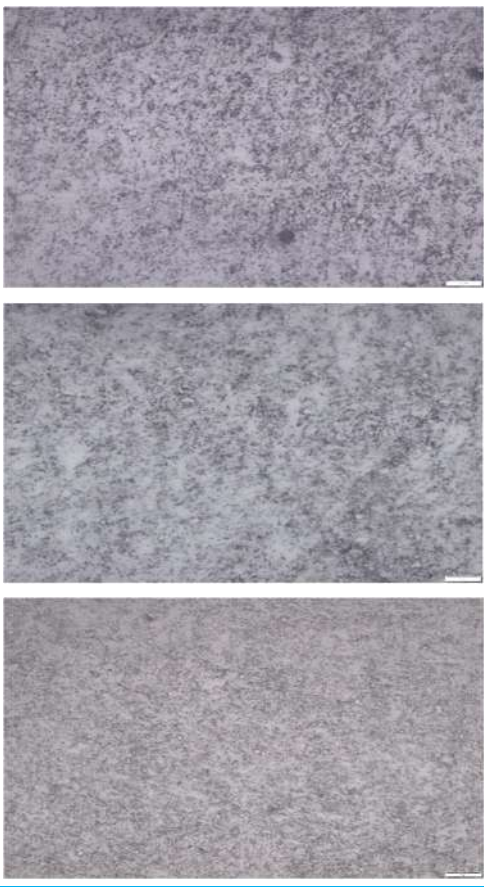
b opz 73 Mofot' h ~ w' hffihqffl' h - p f s' h f o w' f B

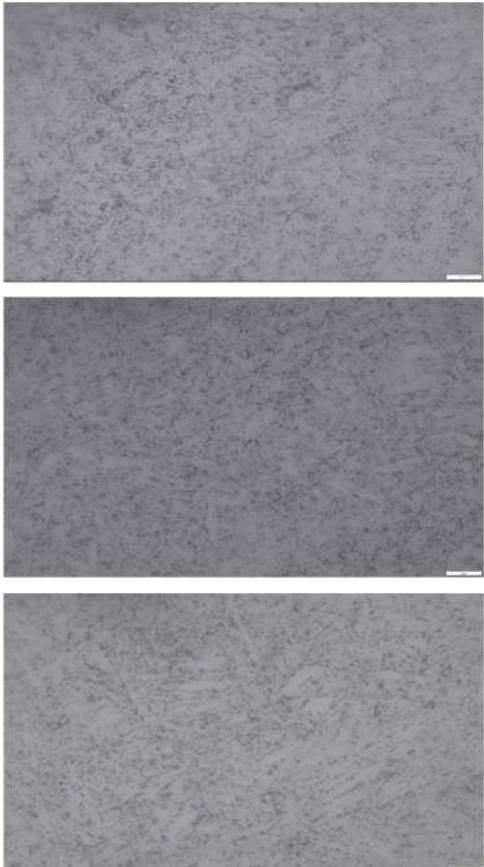
a o ~ z s 4 V - q o f w'	Vopsz	W w' h f f i h q f f l' h
	<p>6J 3</p> <p>6J 3</p> <p>6J 3</p>	
	<p>6K 3</p> <p>6K 3</p> <p>6K 3</p>	

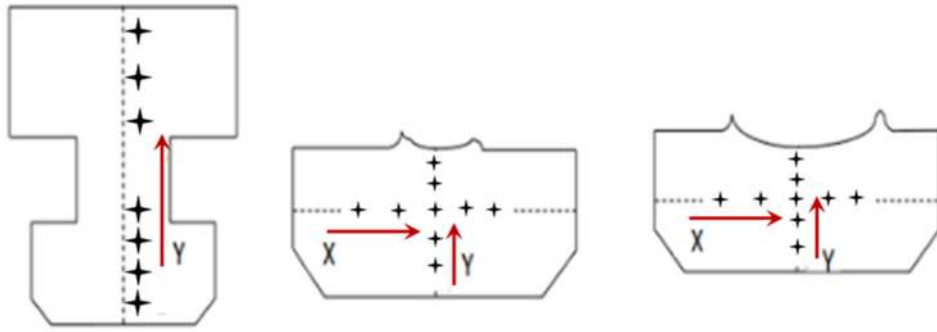

Fig. 3. Microhardness distribution of the samples in the longitudinal and transverse directions.

Table 3. Microhardness distribution of the samples in the longitudinal and transverse directions.

Sample	Material	Longitudinal direction					Transverse direction		
		6	7	8	9	:	;	@	7; A
Sample 6J	g	7@	7@	7@	79A	7:	7;	7B9	7; A
	f	7: 6	796	7@@	79B	7: A			7: :
Sample 69	g	7; A	7; A	7@@	796	79A			7; 5
	f	7AB	77:	79B	7: 6	7A;			7; 5
Sample 6:	g	79:	78@	79B	78A	79:			798

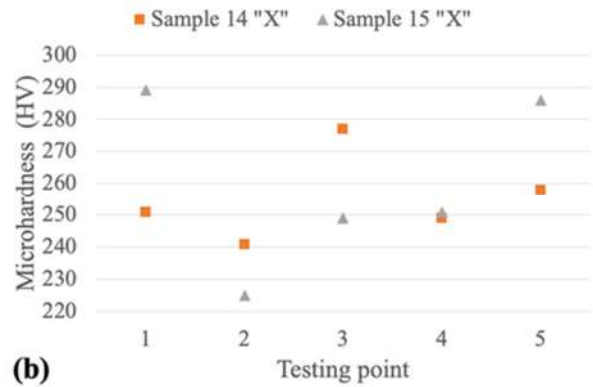
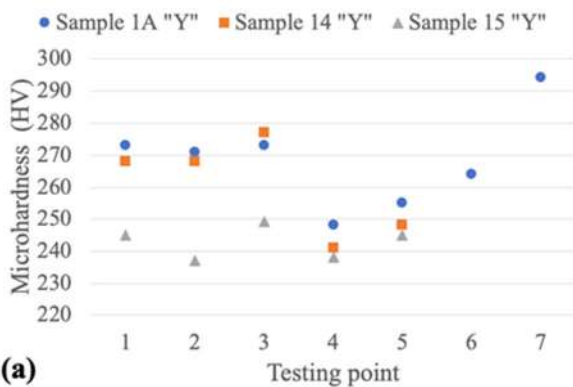

Fig. 4. Microhardness distribution of the samples in the longitudinal and transverse directions.

Results and Discussion

The results of the microhardness measurements are presented in Table 3. The microhardness values of the samples in the longitudinal and transverse directions are in the range of 238–298 HV. The microhardness values of the samples in the longitudinal direction are higher than those in the transverse direction.

The microhardness values of the samples in the longitudinal direction are higher than those in the transverse direction. This is due to the fact that the samples in the longitudinal direction are subjected to a higher degree of deformation during the manufacturing process. The microhardness values of the samples in the transverse direction are lower than those in the longitudinal direction. This is due to the fact that the samples in the transverse direction are subjected to a lower degree of deformation during the manufacturing process.

Conclusions

The microhardness values of the samples in the longitudinal and transverse directions are in the range of 238–298 HV. The microhardness values of the samples in the longitudinal direction are higher than those in the transverse direction. This is due to the fact that the samples in the longitudinal direction are subjected to a higher degree of deformation during the manufacturing process. The microhardness values of the samples in the transverse direction are lower than those in the longitudinal direction. This is due to the fact that the samples in the transverse direction are subjected to a lower degree of deformation during the manufacturing process.

- i 7k aoss' ol a3l sfi oz3 L -fi° zsr ~ sqvo' vqozl ~ sfioz3l Thqoz
o' r QNW pot3r tou3l khw'fis fhuofiw' -t ffs o~ fil Thws
pxrs3 N uwss'kau Cov3l Th J' oz ffil 756: 3 :7C
° 38: 2993
- i 8k U-zou3l Th 3W3sfioz3 Cov3l Tho' oz ffil-t uoffil Thws Th
ffous pxrs ~ ors -t ' vqyszpot3r ffil° s Thz- 3 L off
afflr wff w N uwss'kau Cov3l Th J' oz ffil 756@ AC
° 3; 62; A3
- i 9k Lov or w W3 J' oz3 Us Thfoyo' aflr fl b fl Thw c o°
Wofs Thz WoTh' ffilq afiwzsfil afisz 965 Zor o afius
bs ThvvwThl Thozb sy' w Wsffw Loy Th- 1756B3: -7. C 3
: 62; A3
- i : k Uflpw3y a 1 Th sfi oz3 Cov3l Th o' oz ffil-t fvs 8: 5We
ffs o~ fil Thws pxrs Th-fil N uwss'kau Cov3l Th J' oz ffil
755B36; -9. C 367@267A63
- i ; k L-~ ~ wss1J R3 Cov3lfls o' r Othffl Th 6BB; CJ aW
S fs Thofiw' oz3
- i @k Lvwsffs afv' r oThl PK4b A@272559375591Lvwo SH
o' r afiszS r flffl Th ffil-qvofiw' 3
- i Ak dfly- J b Wo' fl Th uld J 3 3g3 3Be w-tt-1o' r a33
Koffy-Thl Zo' r flo' Wsfiz-u Th 1 sr3 Nj 3 e w-tt-3
75751Toy3 Th CVZ7W Z-zfs y' w Wo' fltoyffl Th ffil3
- i Bk W-p3 1 U3 J --fi L off3 Cov3l Th J' oz ffil 6BBBC
Nffs fvs TK3 3
- i 65k Loz3ffs Th Th e M3 o' r MP 3] sfvtt wq1 Wofs Thzff
ffys' qs o' r s' uwss'kau Co' wffl flqiw' 3A.sr 375651
c' wsr afb3ff-t J ~ s' ThqoCF-v' e vs * a-' flS q3



This article is licensed under a [Creative Commons Attribution 4.0 International License](https://creativecommons.org/licenses/by/4.0/).